

**Supplementary report to the  
type-approval-test of  
gas chromatograph GC 955  
serie 601  
of Synspec**

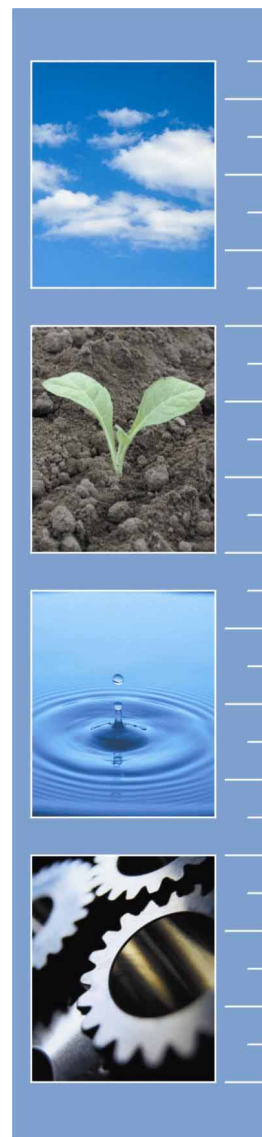

**UMEG**

Umweltmessungen  
Umwelterhebungen  
und Gerätesicherheit

*Unabhängig messen - engagiert prüfen*



**Supplementary report according to  
DIN EN 14662-3  
to the type-approval-test of two  
gas chromatographs of Synspec**

**GC 955 serie 601**

**EDITING:**

Area calibration and repair laboratory (FG 5.3)

Report no.: 53-09/05

Date of printing: 26.04.06

Size: 54 pages



DAP-PL-2921.00

ZLS-P-342/00



**Contents:**

0	Schedular abstract of the test results.....	6
1	Introduction.....	7
2	Basis of the evaluation.....	8
3	Operating mode of the gas chromatograph.....	10
4	Test programme.....	14
4.1	Laboratory tests.....	14
4.2	Field test.....	15
5	Reference measuring method.....	18
6	Test results.....	19
6.1	Lack of fit.....	19
6.2	Short term drift.....	23
6.3	Repeatability.....	25
6.4	Detection limit.....	27
6.5	Dependance on surrounding air temperature.....	30
6.6	Dependence on voltage.....	32
6.7	Interference.....	34
6.8	Carry-over (memory effect).....	43
6.9	Long term drift.....	44
6.10	Maintenance interval.....	47
6.11	Availability.....	48
6.12	Reproducibility standard deviation under field conditions.....	50
6.13	Total uncertainty according to paragraph 8.7 of DIN EN 14662-3 [3].....	52
7	Bibliography.....	54

## 0 Scheduler abstract of the test results

**Table 0.1:** Performance characteristics determined in laboratory tests

Paragraph of the standard	Performance characteristics	Symbol	Performance criterion	Result	Paragraph of the test report
8.5.3	Lack of fit, largest residual	$X_i$	$< \pm 5 \%$	<b>GC 1545:</b> 0,51 % <b>GC 1561:</b> 1,09 %	6.1
8.5.5	Repeatability at zero concentration	$r_{(0,5)}$	$< \pm 0,3 \mu\text{g}/\text{m}^3$	<b>GC 1545:</b> 0,04 $\mu\text{g}/\text{m}^3$ <b>GC 1561:</b> 0,02 $\mu\text{g}/\text{m}^3$	6.3
8.5.5	Repeatability at limit value	$r_{(LV)}$	$< \pm 5 \%$	<b>GC 1545:</b> 0,23 % <b>GC 1561:</b> 0,76 %	6.3
8.5.9.1	Influence of the interference from ozone at span value	$b_{O_3}$	$< \pm 5 \%$	<b>GC 1545:</b> 0,03 % <b>GC 1561:</b> 0,26 %	6.7.1
8.5.9.3	Influence of the interference from sum of possible interfering organic compounds at span value (Concentration of tetrachloromethane $< 1,5 \mu\text{g}/\text{m}^3$ )**	$b_{org}$	$< \pm 5 \%$	<b>GC 1545:</b> 2,5 % <b>GC 1561:</b> 3,8 %	6.7.3
8.5.9.2	Influence of the interference from relative humidity at limit value	$b_{rh}$	$< \pm 4 \%$	<b>GC 1545:</b> 0,13 % <b>GC 1561:</b> 0,42 %	6.7.2
8.5.7	Sensitivity coefficient for the influence of surrounding temperature at span value	$b_{Ts}$	$< \pm 0,2 \%/K$	<b>GC 1545:</b> 0,14 %/K <b>GC 1561:</b> 0,08 %/K	6.5
8.5.8	Sensitivity coefficient for the influence of voltage at span value	$b_V$	$< \pm 0,2 \%/V$	<b>GC 1545:</b> $< 0,01 \%/V$ <b>GC 1561:</b> $< 0,01 \%/V$	6.6
8.5.4	Short term drift at span value (24 h)	$d_{24h}$	$< \pm 5 \%$	<b>GC 1545:</b> 0,65 % <b>GC 1561:</b> 1,04 %	6.2
8.5.10	Carry-over (memory effect)	$Y$	$< 0,5 \mu\text{g}/\text{m}^3*$	<b>GC 1545:</b> 0,14 $\mu\text{g}/\text{m}^3$ <b>GC 1561:</b> 0,10 $\mu\text{g}/\text{m}^3$	6.8

\*: 10 % of the limit value for the first analysis after the response time

\*\* : Both gaschromatographs have an interference  $> 5 \%$  to tetrachloromethane at interferent concentrations  $> 1,5 \mu\text{g}/\text{m}^3$  (see paragraph 6.7.3)

**Table 0.2:** Performance characteristics determined in field tests

Paragraph of the standard	Performance characteristics	Symbol	Performance criterion	Result	Paragraph of the test report
8.6.8	Reproducibility standard deviation	$s_{Rf}$	$< \pm 0,25 \mu\text{g}/\text{m}^3$	0,23 $\mu\text{g}/\text{m}^3$	6.12
8.6.5	Long term drift at span value (14 d)	$d_{14d}$	$< \pm 10 \%$	<b>GC 1545:</b> 4,76 % <b>GC 1561:</b> 4,29 %	6.9
8.6.6	Maintenance interval		$> 14 \text{ d}$	28 d	6.10
8.6.7	Availability	$A_a$	$> 90 \%$	<b>GC 1545:</b> 99,8 % <b>GC 1561:</b> 96,6 %	6.11

# 1 Introduction

Syntech Spectras B.V commissioned UMEG on 06/15/2004 to investigate the suitability of gas chromatograph GC 955 serie 601 for the measurement of immission concentrations of benzene for the purpose of type approval for the analyser in Germany.

The laboratory and the following field tests were carried out in accordance with the specifications of VDI directive 4202 part 1 (June 2002) [1] and VDI directive 4203 part 3 (August 2004) [2] with regard to DIN EN 14662-3 (August 2005) [3].

The tests were concluded successfully in July 2005 by editing the suitability evaluation report (see UMEG report 53-3/05 [4]). At the meeting of the working group „evaluation reports“ on 16th and 17th of August 2005 the type approval was then recommended to the subcommittee of the LAI and finally published in the German Federal Gazette of 10/29/2005.

In the present report the evaluated measuring data were analysed und summarised according to the specifications of DIN EN 14662-3 [3]. Possible differences to the values of the UMEG report 53-3/05 [4] referenced above are to be put down to the modified requirements of the VDI directives and the DIN standard (e.g. linearity, dependence on temperature). Moreover, the results in the present report of concentrations given in [ $\mu\text{g}/\text{m}^3$ ] were standardised to the surrounding conditions of 1013 hPa and 293 K, whereas the results in the actual type-approval-test-report are standardised to the surrounding conditions of 1013 hPa and 273 K. This was the initial setting taken by the manufacturer.

## 2 Basis of the evaluation

The tests were performed according to the terms and definitions of the following directives:

**VDI directive 4202 part 1 (June 2002) [1]**

Minimum requirements for automatic immission test equipment for the suitability evaluation.  
Point measuring method for gaseous air pollutants and particles.

**VDI directive 4203 part 3 (August 2004) [2]**

Test plans for automatic test equipments  
Test procedure for test equipments for the punctiform measurement of gaseous immissions and particles

**DIN EN 14662-3 (August 2005) [3]**

Ambient air quality – Standard method for the measurement of benzene concentrations –  
Part 3: Automated pumped sampling with in situ gas chromatography

**Equipment under test (EUT):**

Gas chromatograph GC 955 serie 601



**Fig. 2.1:** Front of the EUT

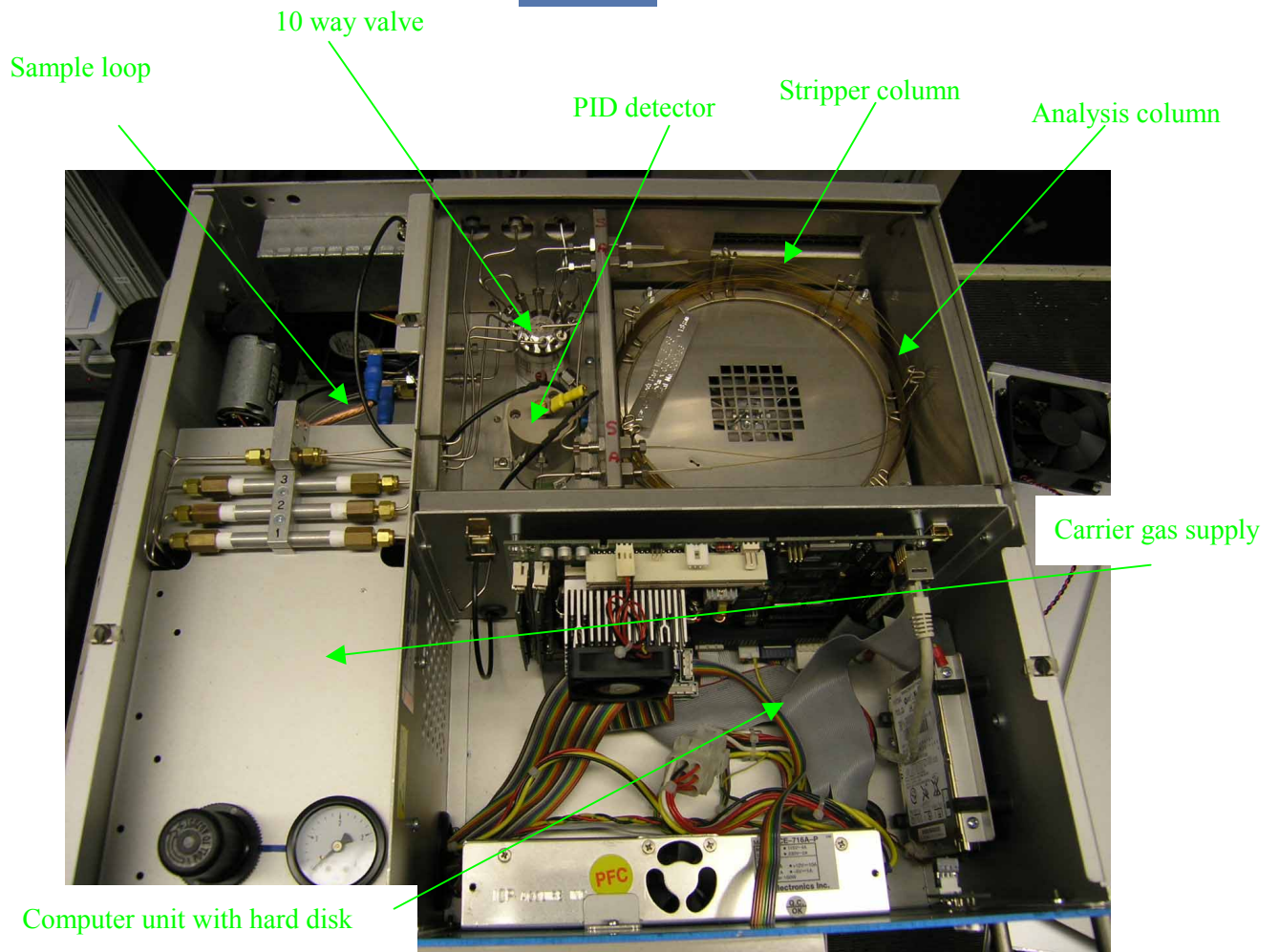

Fig. 2.2: Interior of the EUT



Fig. 2.3: Rear of the EUT

### 3 Operating mode of the gas chromatograph

The gas chromatograph GC 955 serie 601 is an analyser for the automatic, continuous measurement of benzene, toluene and m / p- and o-xylene in the ambient air including concentrating sampling, thermal desorption and finally gas chromatographical separation.

**Operating procedure:**

Initially the sample lines are rinsed by a pump. Afterwards the medium being measured is accumulated in a sample loop (absorber Tenax GR) by means of a sample cylinder (sample volume setting: 175 ml) and in a second step thermally desorbed. Heating the sample loop rapidly effects a very quick desorption of the components, as the carrier gas (nitrogen) passes the sample loop in the counter flow (see figure 3.1).

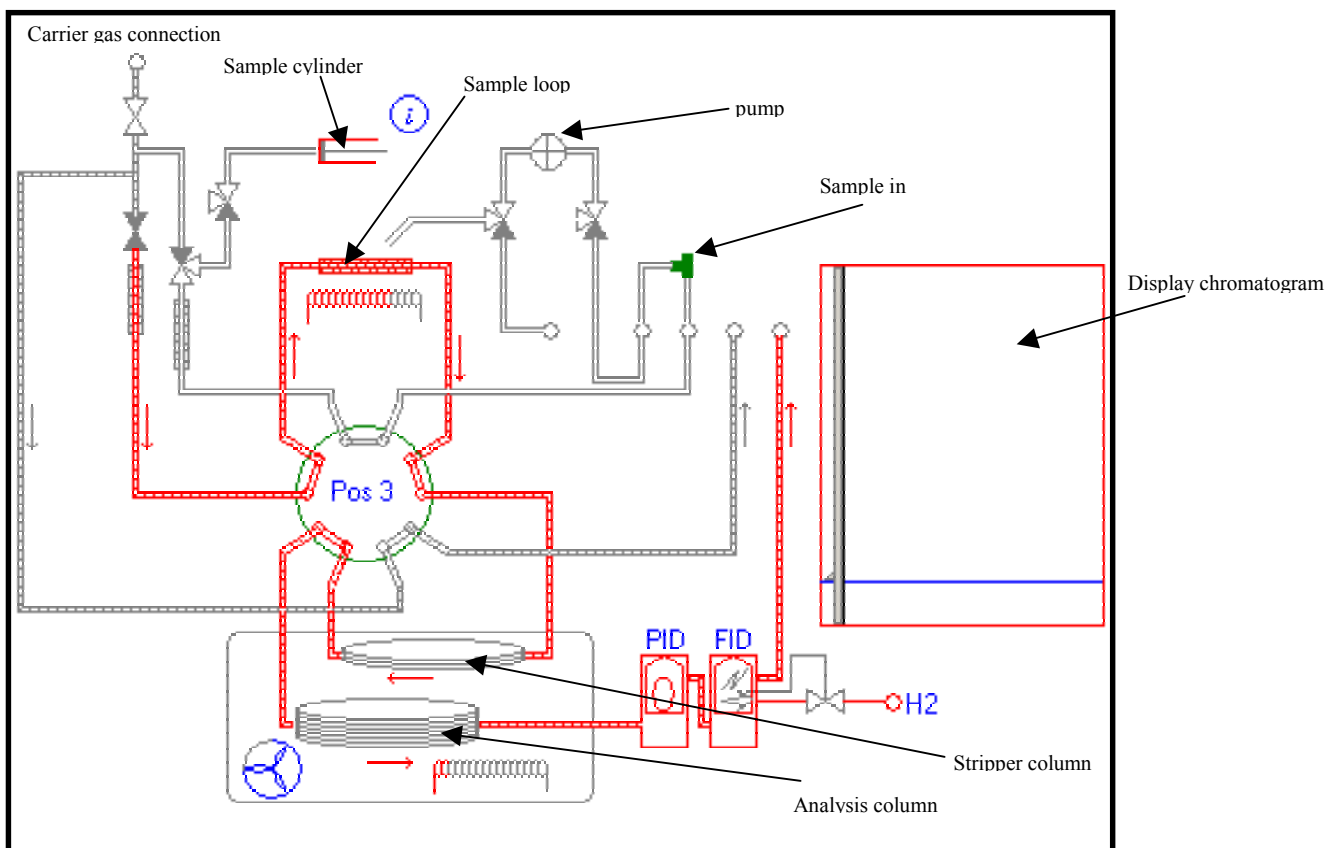

**Fig. 3.1:** Diagram of the thermal desorption (FID can be omitted after evaluation)

Afterwards the sample reaches the separation column; the single steps are controlled by the different positions of a 10-way valve. The separation column comprises two elements: a stripper column and a analysis column, both of identical material. After the relevant components have left the stripper column, the non relevant components are rinsed out of it by switching the 10-way valve to counter position (see figure 3.2).

During this procedure the actual medium being measured reaches the analysis column, where the components are finally separated and analysed in a photo ion detector (PID).

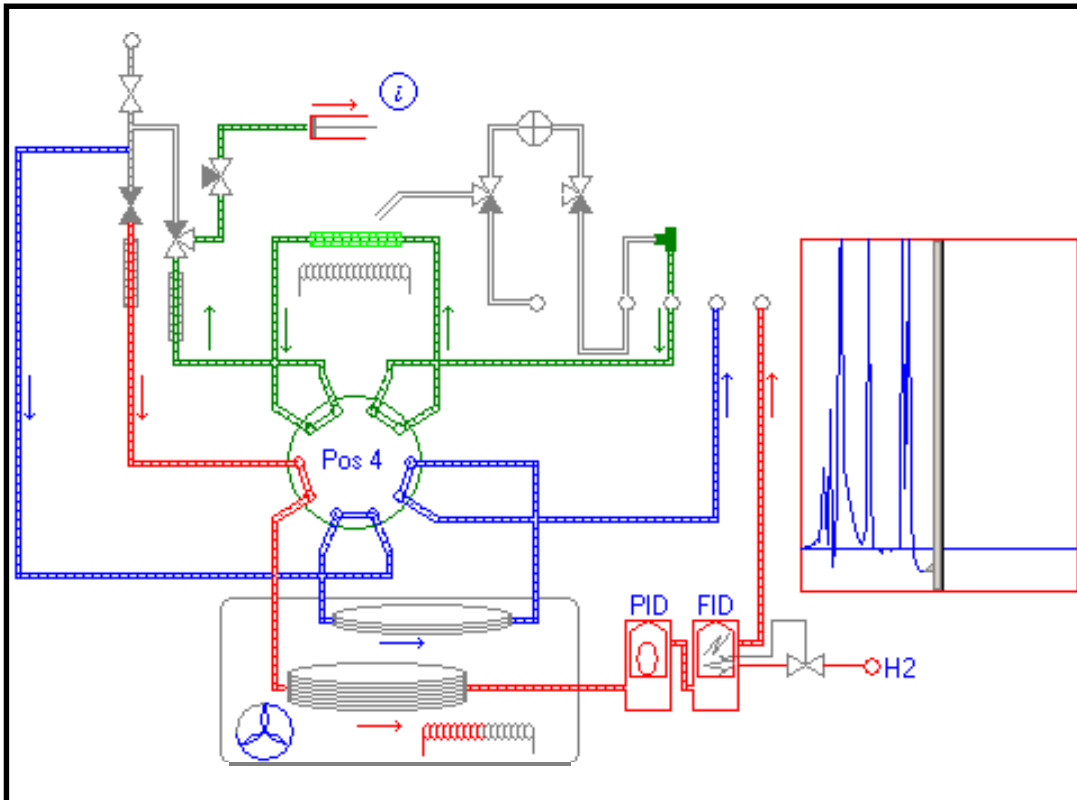

**Fig. 3.2:** Way of the gas for the sampling, rinsing of the stripper column and analysis of the components

The analysis is performed by a temperature programme, by which the compounds can be separated and determined within a short cycle at highly diverse boiling points. During the temperature programmed separation the oven is heated up by 20 K over the basic temperature (60°C) within two minutes (see fig. 3.3). After five minutes at 80°C it is cooled down to the basic temperature, before the next analysis cycle starts. This proceeding allows a short analysis period (15 minutes).

During the measuring, radiation energy excites the electrons in the photo ion detector till they are separated from their atom or molecule. A discharge lamp filled with inert gas and under low pressure, which generates a stable monochromatic energetic luminous flux of photons, constitutes the energy source for the ionisation.

The ultraviolet lamp is installed closely in the detector. The light source is separated from the carrier gas flux by a UV-translucent window of magnesium fluorid. The PID response is boosted, digitised and saved. The resulting chromatogram can be watched on the LCD-display in real time; for the components to be analysed the peak value or the peak area is calculated and charted.

For the control of the GC955 a standard CPU is used. The electronics are developed especially for the GC. The instrument is provided with electronic sensors for monitoring the carrier gas flux and the pressure for

the switching of the valve. The measured values are displayed continuously on the monitor in the footer below the chromatogram.

In the same menu the ongoing cycle can be watched, saved chromatograms can be retrieved and the setting of the control program can be modified. These modifications are easily to be carried out in a bar chart. However, a password protection prevents from unauthorised modification.

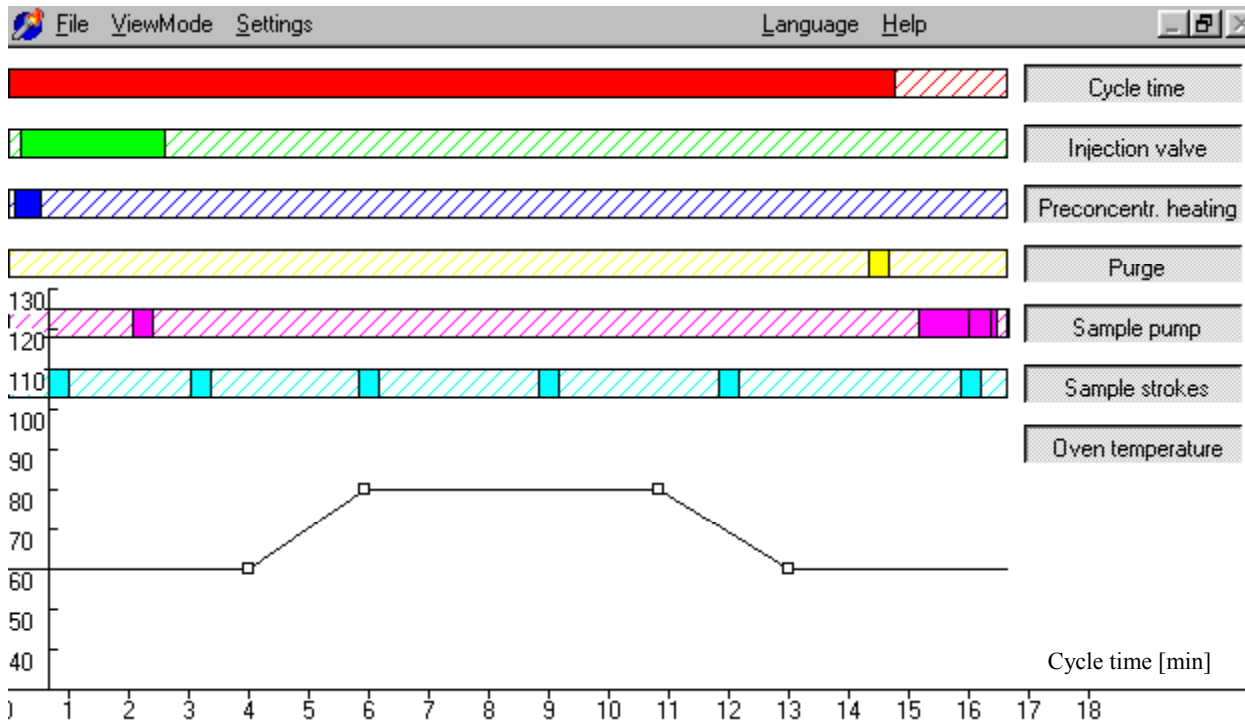

**Fig. 3.3:** Control program for one test cycle (15 min.)

**Technical data of the tested instruments:**

Absorber in the sample loop:	Tenax GR 35/60
10-way valve:	O3W-0031D
Carrier gas:	Nitrogen 5.0
Column type:	Alltech AT 624 (ID: 0,32 mm; film: 1,8 µm)
Analysis columnlength:	13 m
Stripper columnlength:	2 m
Detector:	PID 10,6 eV (L 845)
Measuring cell volume:	50 µl
Monitor size:	LCD 11''
CPU:	Cyrix M II / IBM 300
Main memory:	64 MB
Hard disk:	20 GB Fujitsu MHR 2020AT
Software version:	4.0.5
Interface:	I/O RS232
Power supply:	230 V AC; 50 Hz
Power demand:	115 VA (average); 600 VA (peak value)
Size:	19''-rack with 5 HE (= 23,2 cm), depth 37,2 cm
Sample volume setting:	5 strokes a 35 ml per test cycle (= 175 ml)

## 4 Test programme

### 4.1 Laboratory tests

For the laboratory tests both gas chromatographs were installed in a 19''-rack in the test laboratory of UMEG (see fig. 4.1.1).

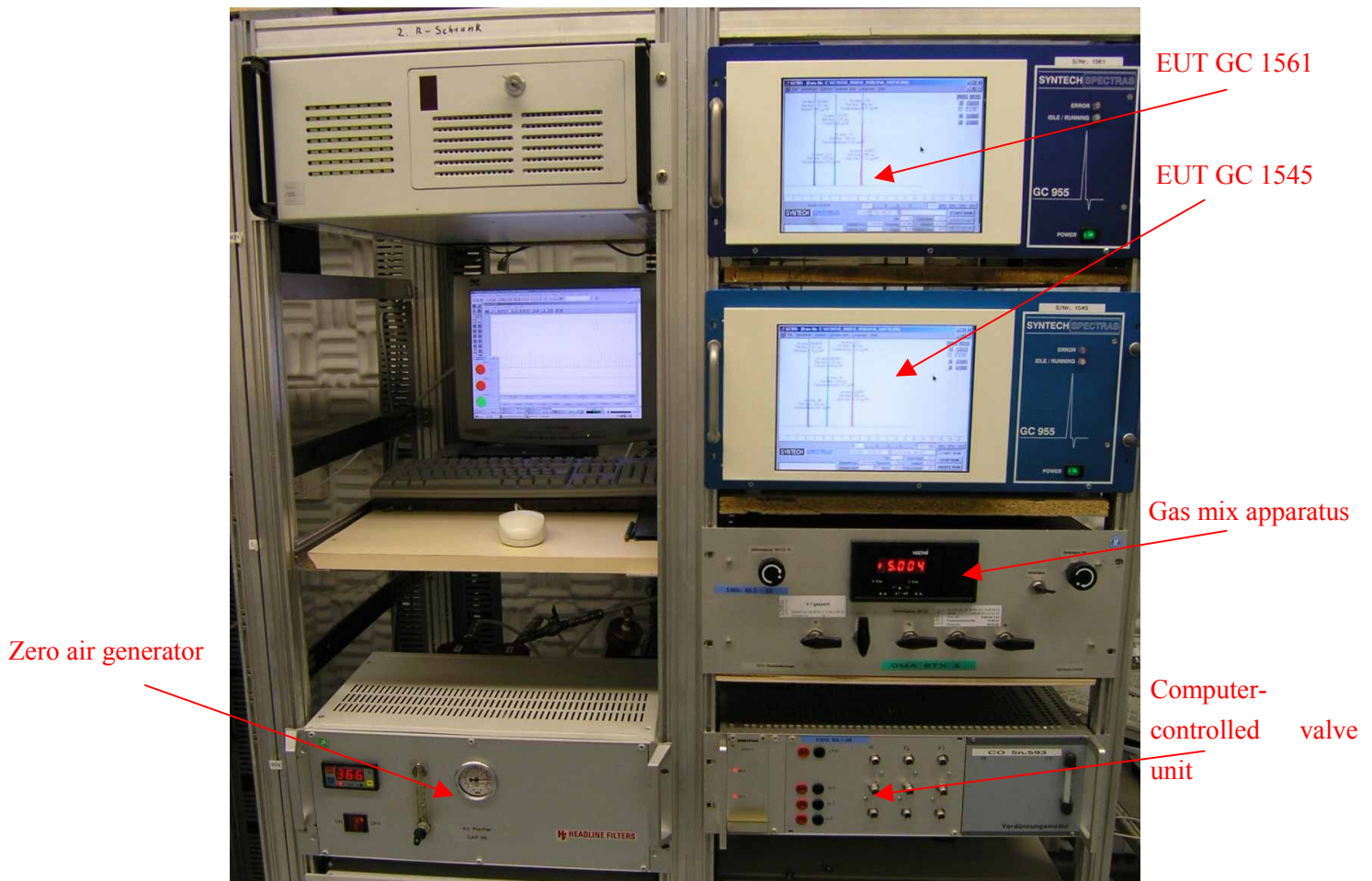

**Fig. 4.1.1:** Setup of the measuring station for the laboratory tests

The setup of the measuring station included additionally a gas mix apparatus according to VDI directive 3490 part 16 „Messen von Gasen - Prüfgase - Herstellen von Prüfgasen mit Blenden-Mischstrecken“ [5] and a catalytic zero air generator of Headline-Filters (Air Purifier CAP 60).

By means of the gas mix apparatus a pre-mix from a compressed gas cylinder at a benzene concentration of  $10,2 \text{ mg/m}^3$  together with zero gas was diluted to the concentration range of  $0,5 - 490 \text{ } \mu\text{g/m}^3$ . The modulation of the dilution was controlled by the modification of both volume flows (zero gas and benzene addition). Volumeters of Brooks (accredited volume standards) provided the correct definition of these volume flows.

The zero air generator serves to the production of zero gas (purified compressed air) for the gas mix apparatus mentioned above as well as to the zero air supply.

For the tests referring to the dependence on temperature the EUTs were installed into a climate chamber VC 4034 of *Vötsch*.

For the automation of several laboratory tests and for the field test (see paragraph 4.2) a computer-controlled valve unit (UMEG self-made) was used, with the option to switch over to different test situations (span gas, zero gas, sample gas).

## 4.2 Field test

For the field test both gas chromatographs were installed in a gauging station on the test site opposite to the UMEG-building very close to a road with a considerable traffic volume (feeder road).

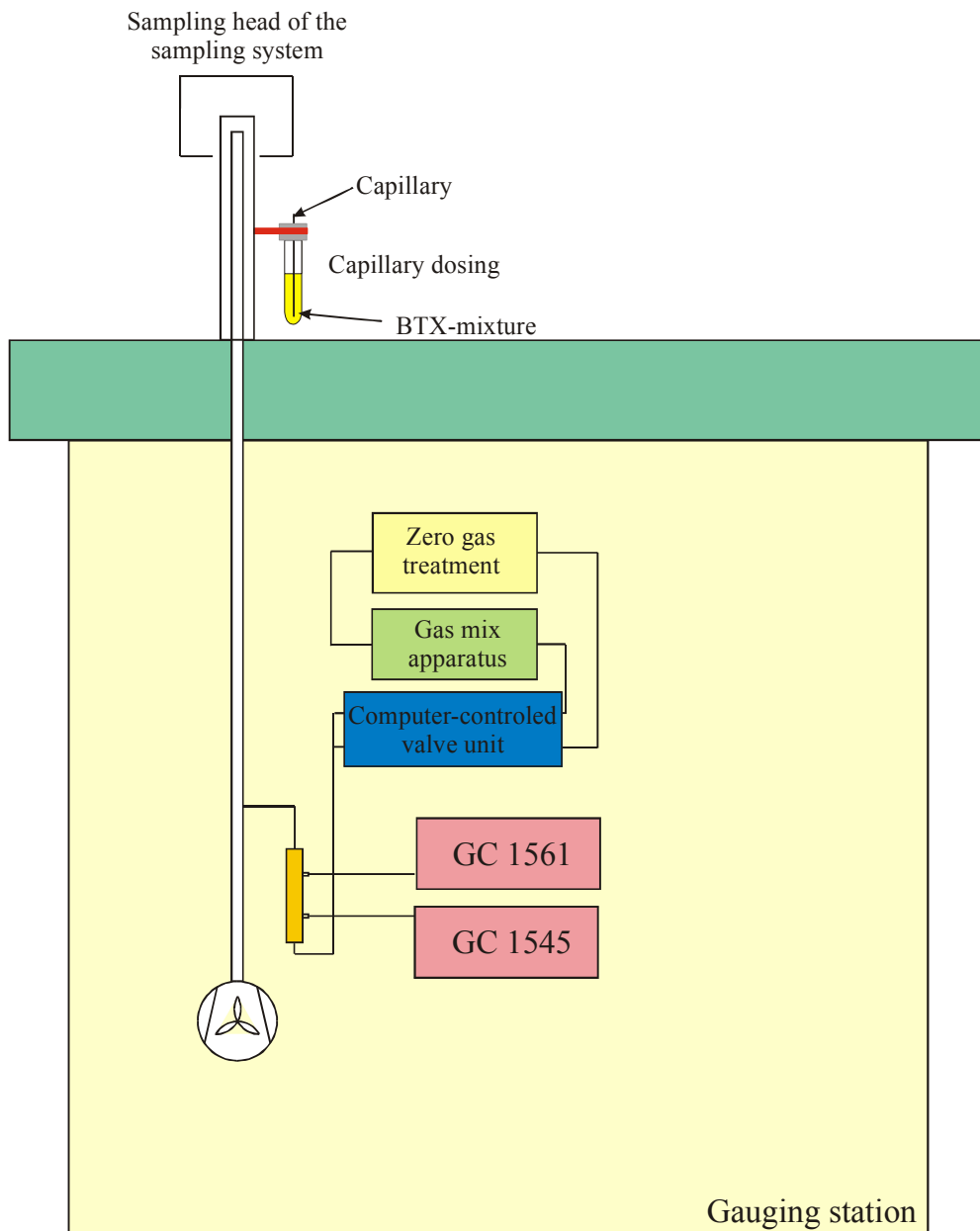

**Fig. 4.2.1:** Gauging station on the test site of UMEG

Both instruments were installed in a 19''-rack inside the air-conditioned station ( $T = 20^{\circ}\text{C} \pm 3^{\circ}\text{C}$ ) and connected to the sampling system of the station (sample tube including a standardised sampling head on the

roof). This configuration guaranteed that both instruments performed a representative measurement of the same sample air volume.

The benzene concentrations at the site of the employed gauging station are determined constantly. The evaluated annual averages are about  $3 \mu\text{g}/\text{m}^3$ . Since a minimum amount of data of readings about the reference value  $B_1 = 10 \mu\text{g}/\text{m}^3$  is required, a capillary dosing element containing a BTX mixture (glass vessel with metallic capillary) was attached below the sampling head of the sampling system (see fig. 4.2.2).



**Fig. 4.2.2:** Schematic chart of the test setup for the field test

A certain amount of benzene emitted from this dosing element depending on the surrounding temperature and the atmospheric pressure, and was absorbed incidentally by the sample air flow depending on wind direction. Thus, benzene concentrations up to  $100 \mu\text{g}/\text{m}^3$  were measured at the beginning of the field test (5th to 7th of February). To avoid memory effects in the sampling system, the distance of the dosing unit to the sampling head was extended. As from this moment the benzene concentrations were between  $1 \mu\text{g}/\text{m}^3$  and  $40 \mu\text{g}/\text{m}^3$  during the entire field test.

For the data transfer to the measurement network centre of UMEG the instruments were connected to the computer of the station, which is equipped with a data logging system, via the internal interface RS232. For the communication between the gas chromatographs and the computer of the station the „*Bayern-Hessen-Protokoll*“ was used.

For the daily function control, additionally to the test setup the gas mix apparatus was used (see paragraph 4.1), which was already employed for the span gas production for the laboratory tests. For the production of zero gas the in-station zero gas treatment was used (compressor with downstream air purifying of *Breitfuß*). The daily function control was carried out by a computer-controlled valve unit (see paragraph 4.1), which switched over to zero gas, span gas and ambient air measuring.

## 5 Reference measuring method

Since not required, there was no reference measuring method employed for the suitability evaluation of the gas chromatograph. However, the traceability of the employed span gases to reference normals has to be guaranteed.

At UMEG, the employed BTX span gases are traced back to the basis method of continuous application [6]. A gadget of *Axel Semrau Modell KS 493 C* is employed.

For the generation of a reference gas the pure substances are vapourised from the liquid phase and then diluted to the ppm-range by zero air. For this purpose, a BTX component mix is drawn in an internal flask buret with a volume of 1 cm<sup>3</sup> before it is injected into an injector at low infeed (0,04 - 0,4 ml/h). The injected liquid vapourises in the injector and is mixed to a zero gas flow of zero air (20 - 400 ml/min). This mixture reaches a mix chamber of about 1,5 l volume via a buffer volume and is there diluted again by a zero air flow of 0 - 10 l/min. Applying the above indicated parameters, reference gases at the concentration range of 3 - 30 ppm can be generated.

A reference gas, which is generated by the method of continuous application and thus has a known concentration, is applied to a laboratory gas chromatograph (Agilent GC 6850). Afterwards the span gas cylinder to be determined, which contains the span gas at unknown concentration, is connected to this gas chromatograph. The concentration of the span gas is calculated by comparing the peak areas of the gas mixtures. The span gas cylinder analysed that way is connected to the gas mix apparatus (see paragraph 4.1) and utilised for the production of span gases at low concentration ranges (0,5 – 490 µg/m<sup>3</sup>).

The refeed of the span gas is carried out regularly according to the specifications of the quality management system to be applied in the laboratory in compliance with DIN EN ISO/IEC 17025 [7] (QM instruction V 506-53108 „Production and supply of standards in the calibration laboratory for aromatic hydrocarbons (benzene, toluene, p-xylene) as well as chlorinated hydrocarbons“).

## 6 Test results

### 6.1 Lack of fit

#### 6.1.1 Requirement according to point 8.5.3 of DIN EN 14662-3 [3]

The largest relative residual from the linear regression function shall be less than  $\pm 5\%$ . When one or more of the relative residuals does not meet the criterion, then the analyser does not pass the linearity test.

#### 6.1.2 Test conditions

A linear regression function is determined from the responses of the analyser and the corresponding applied concentration level. The residual at each concentration level is equal to the difference between the average response measured, expressed as a concentration, and the concentration given by the linear regression function. The calculation of the linear regression function and residuals shall be performed according to Annex A of DIN EN 14662-3 [3].

The linearity of the analyser shall be tested over the range between 0 % and 90 % of the maximum of the certification range, using at least six concentrations (including the zero point).

The residuals of the averages of each calibration point (excluding the zero point) are calculated according to Annex A.2 of DIN EN 14662-3 [3] as follows:

$$(Y_a)_c = \frac{\sum (Y_i)_c}{m} \quad (\text{Gl. 6.1})$$

where

- $(Y_a)_c$  is the average Y-value at concentration level c;
- $(Y_i)_c$  is the individual Y-value at concentration level c;
- m is the number of repetitions at the same concentration level

The residual of each average ( $d_c$ ) at the 5 concentration levels is calculated according to:

$$d_c = (Y_a)_c - (A + B \cdot c) \quad (\text{Gl. 6.2})$$

where

- A: is the axis intercept of the calibration function
- B: is the slope of the calibration function

Each residual to a value relative to its own concentration level c is expressed as:

$$(d_r)_c = \frac{d_c}{c} \cdot 100\% \quad (\text{Gl. 6.3})$$

The largest value of  $(d_r)_c$  is reported as  $X_{\text{fit}}$  and shall be included in the uncertainty calculation.

The standard uncertainty  $u_{\text{fit, LV}}$  due to lack of fit at the limit value is calculated according to:

$$u_{\text{fit, LV}} = \frac{X_{\text{fit}} \cdot c_{\text{LV}}}{\sqrt{3}} \cdot \frac{1}{100} \quad (\text{Gl. 6.4})$$

Where

- $u_{\text{fit, LV}}$  : is the standard uncertainty due to lack of fit at the limit value;
- $X_{\text{fit, LV}}$  is (according to Annex A) the calculated residual from the linear regression function at the limit value (%);
- $c_{\text{LV}}$  is the limit value.

### 6.1.3 Assessment

The requirement of the standard is met.

### 6.1.4 Documentation

Five different span gas concentrations over the measurement range up to 50 µg/m<sup>3</sup> as well as zero concentration were applied to both gas chromatographs by means of the gas mix apparatus as described in paragraph 4.1.

Each concentration was applied for one hour (4 test cycles of 15 minutes = 4 readings) over five successive calibration cycles. Only the last three readings of one hour were included in the analysis. Thus, 15 readings for each concentration level and the resulting averages were determined. The calibration and the analysis function were calculated through the regression calculation (see table 6.1.1). The calibration functions of both gas chromatographs are charted in figure 6.1.1 and 6.1.2.

**Table 6.1.1:** Calibration and analysis function of the gas chromatographs 1545 and 1561

	<b>GC 1545</b>	<b>GC 1561</b>
<b>Calibration function</b>	$y = 53304 x + 7512$	$y = 37815 x + 6659$
<b>Analysis function</b>	$x = (y - 7512) / 53304$	$x = (y - 6659) / 37815$

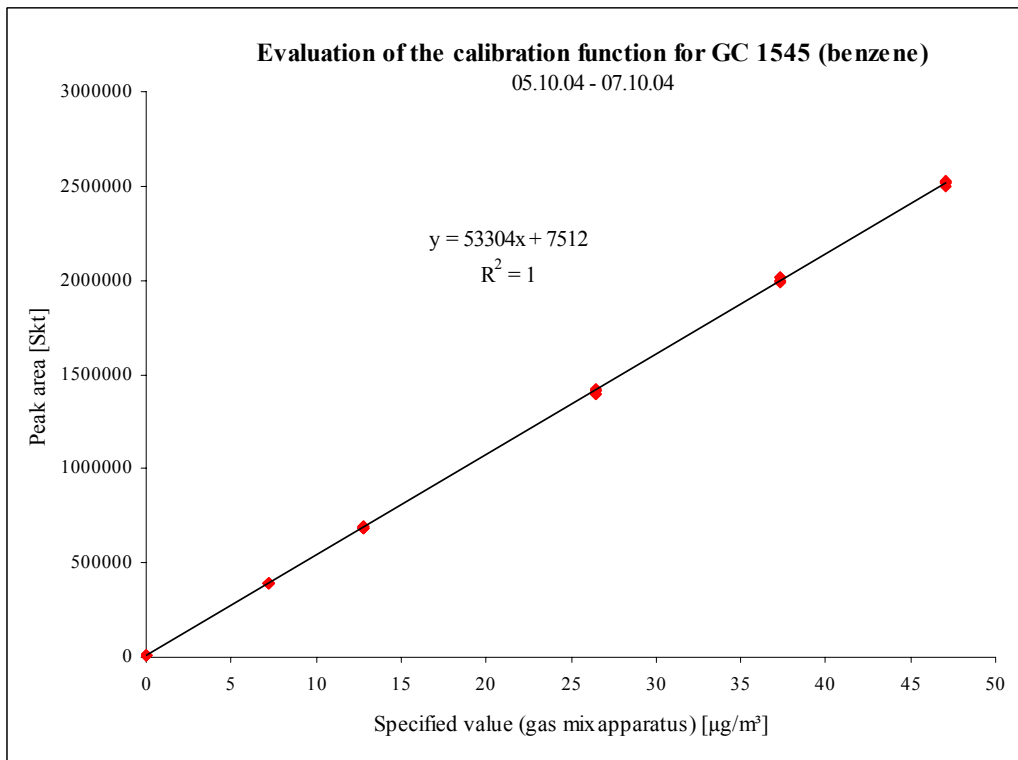

**Fig. 6.1.1.:** Chart of the calibration function of GC 1545

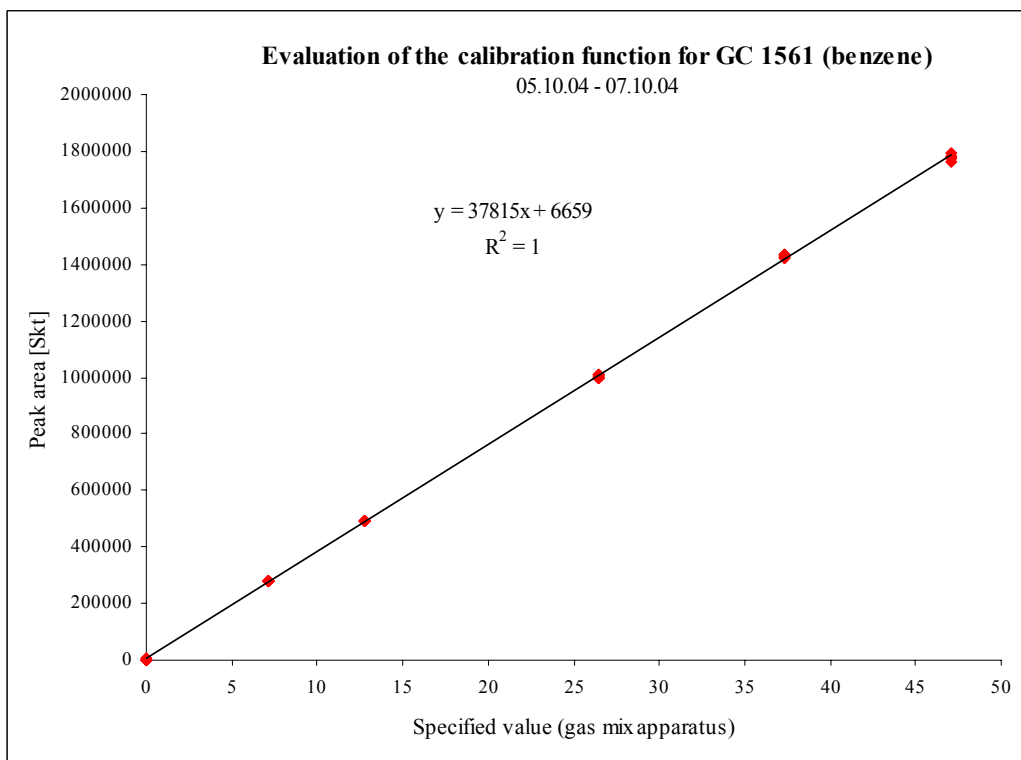

**Fig. 6.1.2.:** Chart of the calibration function of GC 1561

**Table 6.1.2:** Residuals of the averages of each calibration point (excluding the zero point) for GC 1545

Cycle	c [ $\mu\text{g}/\text{m}^3$ ]	Peak area [Skt]	(A + B *c)	d <sub>c</sub>	(d <sub>r</sub> ) <sub>c</sub>
Average 1 – 5 (Y <sub>a</sub> ) <sub>c</sub>	7,16	390379	389167	1212	0,31
Average 1 – 5 (Y <sub>a</sub> ) <sub>c</sub>	12,77	685881	688201	-2320	-0,34
Average 1 – 5 (Y <sub>a</sub> ) <sub>c</sub>	26,44	1409643	1416863	-7219	-0,51
Average 1 – 5 (Y <sub>a</sub> ) <sub>c</sub>	37,36	2003961	1998939	5022	0,25
Average 1 – 5 (Y <sub>a</sub> ) <sub>c</sub>	47,08	2517566	2517051	514	0,02

From this calculation results for GC 1545:

Standard uncertainty  $u_{\text{fit, LV}}$  0,015

Limit value  $c_{\text{LV}}$  [ $\mu\text{g}/\text{m}^3$ ] 5,00

**Largest residual  $X_{\text{fit}}$  0,51**

**Table 6.1.2:** Residuals of the averages of each calibration point (excluding the zero point) for GC 1561

Cycle	c [ $\mu\text{g}/\text{m}^3$ ]	Peak area [Skt]	(A + B *c)	d <sub>c</sub>	(d <sub>r</sub> ) <sub>c</sub>
Average 1 – 5 (Y <sub>a</sub> ) <sub>c</sub>	7,16	280431	277417	3014	1,09
Average 1 – 5 (Y <sub>a</sub> ) <sub>c</sub>	12,77	490895	489562	1333	0,27
Average 1 – 5 (Y <sub>a</sub> ) <sub>c</sub>	26,44	1002579	1006498	-3919	-0,39
Average 1 – 5 (Y <sub>a</sub> ) <sub>c</sub>	37,36	1429062	1419442	9619	0,68
Average 1 – 5 (Y <sub>a</sub> ) <sub>c</sub>	47,08	1780756	1787008	-6252	-0,35

From this calculation results for GC 1561:

Standard uncertainty  $u_{\text{fit, LV}}$  0,031

Limit value  $c_{\text{LV}}$  [ $\mu\text{g}/\text{m}^3$ ] 5,00

**Largest residual  $X_{\text{fit}}$  1,09**

## 6.2 Short term drift

### 6.2.1 Requirement according to point 8.5.4 of DIN EN 14662-3 [3]

The short term drift at span value  $d_{24h}$  under laboratory conditions over a drift period of 24 hours shall be less than  $\pm 5 \%$ .

### 6.2.2 Test conditions

The instrument is kept running under laboratory conditions whilst applying span gas at the span level ( $50 \mu\text{g}/\text{m}^3$ ). From 4 successive measurements the mean value is calculated. After a period of 24 hours the measurements at span value are repeated.

The short term drift at span level is calculated as follows:

$$d_{24h} = \frac{|c_{n,MW} - c_{n-1,MW}|}{c_{n,MW}} \cdot 100\%$$

Where

$d_{24h}$  is the drift at span concentration  $c_t$  as percentage;

$c_{n, MW}$  is the average of the 4 analyses at the beginning of the drift period;

$c_{n-1, MW}$  is the average of the 4 analyses at the end of the drift period (24 h).

The standard uncertainty  $u_s$  due to short term drift shall be calculated as follows in accordance with ENV 13005:

$$u_s = \frac{c_{n,MW} - c_{n-1,MW}}{2\sqrt{3}}$$

The result of the short term drift is not included in the total uncertainty.

### 6.2.3 Assessment

The requirement of the standard is met.

### 6.2.4 Documentation

The readings, which were calculated by the determination of the calibration function, were used for the calculation of the short term drift under laboratory conditions. In this test each concentration was applied over the period of one hour (4 test cycles of 15 minutes = 4 readings) in five successive calibration cycles. Thus, five averages for the concentration level were determined over the range of the span level. For the drift determination average 1 and average 4 were compared as well as average 2 and average 5, each measured in intervals of 26 hours. The corresponding data for both gas chromatographs GC 1545 and GC 1561 are presented in table 6.2.1.

**Table 6.2.1:** Averages of the concentration levels over the range of the span level

	GC 1545		GC 1561	
	[ $\mu\text{g}/\text{m}^3$ ]	Peak area	[ $\mu\text{g}/\text{m}^3$ ]	Peak area
Average 1	46,76	2499997	46,57	1767905
Average 2	47,26	2526399	46,87	1779231
Average 3	47,14	2520268	47,33	1796294
Average 4	47,06	2516214	47,06	1786202
Average 5	46,98	2511619	46,82	1777175

Following values for the short term drift  $d_{26h}$  and for the standard uncertainty  $u_s$  result from above averages:

	GC 1545	GC 1561
$d_{26h, 1}$	<b>0,65</b>	<b>1,04</b>
$d_{26h, 2}$	<b>0,59</b>	<b>0,12</b>
$u_{s, 1}$	-0,09	-0,14
$u_{s, 2}$	0,08	0,02

## 6.3 Repeatability

### 6.3.1 Requirement according to point 8.5.5 of DIN EN 14662-3 [3]

The repeatability  $r_i$  at the zero point shall be less than  $\pm 0,3 \mu\text{g}/\text{m}^3$  and the repeatability  $r_i$  at the limit value ( $= 5 \mu\text{g}/\text{m}^3$ ) shall be less than  $\pm 5 \%$ .

### 6.3.2 Test conditions

The standard deviations of 10 successive individual measurements at the limit value, and at approximately 1/10 of the limit value, are calculated according to the following equation.

$$s_r(c) = \sqrt{\frac{\sum_{i=1}^n (c_{\text{test};i} - c_{\text{test};MW})^2}{n-1}}$$

Where

- $s_r(c)$  is the repeatability standard deviation at the measurand level  $c$ ;
- $c_{\text{test};i}$  is the  $i$ -th individual measurement at measurand level  $c_{\text{test}}$ ;
- $c_{\text{test};MW}$  is the average of the individual measurements at measurand level  $c_{\text{test}}$ ;
- $n$  is the number of individual measurements.

The repeatability ( $r_i$ ) is calculated according to

$$r = t_{n-1;0,05} \cdot s_r$$

Where

- $t_{n-1;0,05}$  is the two-sided Student's t-factor at a confidence level of 0,05 with  $n-1$  degrees of freedom;
- $s_i$  is the repeatability standard deviation ( $\mu\text{g}/\text{m}^3$ ).

The repeatability standard uncertainty  $u_r$  is determined by:

$$u_r = s_r$$

### 6.3.3 Assessment

The requirement of the standard is met.

### 6.3.4 Documentation

For the calculation of the repeatability initially zero air, then span gas over the range of the limit value was applied with a repetition factor of 10.

Table 6.3.1 shows the results at application of zero concentration for both gas chromatographs GC 1545 and GC 1561.

**Table 6.3.1:** Repeatability at zero concentration

	<b>GC 1545</b>	<b>GC 1561</b>
Repeatability standard deviation. $s_r = u_r$ [ $\mu\text{g}/\text{m}^3$ ]	0,02	0,009
Student's factor t	2,26	2,26
<b>Repeatability <math>r_i</math> [<math>\mu\text{g}/\text{m}^3</math>]</b>	<b>0,04</b>	<b>0,02</b>

To draw a comparison of the performance criterion  $K_L$  with the specification of the standard ( $K_L < \pm 5\%$ ) at application of span concentration, the measurand is calculated according to the following equation:

$$K_L = \frac{u_r \cdot 100\%}{C}$$

Where

C: is the maximum occurring concentration of benzene [ $\mu\text{g}/\text{m}^3$ ]

Table 6.3.2 shows the results at application of span concentration for both gas chromatographs GC 1545 and GC 1561.

**Table 6.3.2:** Repeatability at limit value

	<b>GC 1545</b>	<b>GC 1561</b>
Repeatability standard deviation. $s_r = u_r$ [ $\mu\text{g}/\text{m}^3$ ]	0,015	0,054
Student's factor t	2,26	2,26
Repeatability $r_i$ [ $\mu\text{g}/\text{m}^3$ ]	0,03	0,12
Maximum benzene concentration [ $\mu\text{g}/\text{m}^3$ ]	6,71	7,10
<b>Performance criterion <math>K_L</math> [%]</b>	<b>0,23</b>	<b>0,76</b>

## 6.4 Detection limit

### 6.4.1 Requirement according to DIN EN 14662-3 [3]

The DIN EN 14662-3 [3] does not specify any requirements for the detection limit of the gas chromatographs, which are to be tested. However, it is indispensable to determine the detection limit for the assessment and the evaluation of the measured readings over the range of the 0,1-fold limit value.

### 6.4.2 Test conditions

The determination of the detection limit is carried out by means of the blank value method: external, alternating application of zero and span concentration free of pressure to the test apparatus with sufficient reserve and 15 individual measurements at each concentration.

### 6.4.3 Assessment

Omitted

### 6.4.4 Documentation

For the determination of the detection limit span gas and zero air were applied to the test instruments alternately over the period of one hour (4 test cycles) with a repetition factor of 15. The span concentration was defined over the range of 10 µg/m<sup>3</sup>. The last three test cycles of each hour with zero concentration were included in the analysis, each initial test cycle was considered as transitional value and rejected.

This test was carried out during the laboratory tests and repeated at the end of the field test.

The detection limit was calculated according to the following equation:

**Detection limit (DL):**  $x_{NW} = 1/m * (y_{NW} - A)$

**Value at DL:**  $y_{NW} = y_0 + t_{n-1; 0,95} * s_{y0}$

$y_0$ :	Average of the measured zero values [Skt]
$y_{NW}$ :	Value at detection limit [Skt]
$x_{NW}$ :	Detection limit [µg/m <sup>3</sup> ]
$s_{y0}$ :	Standard deviation of the measured zero values
$t_{n-1; 0,95}$ :	Student's factor
$m$ :	Slope of the calibration function
$A$ :	Intercept of the calibration function

The results of both tests are summarised in table 6.4.1 and 6.4.2.

**Table 6.4.1:** Readings for the determination of the detection limit for GC 1545

Cycle	Before field test	After field test
	Peak area [Skt]	Peak area [Skt]
1	17377	6688
2	15564	7339
3	14208	7684
4	15602	8472
5	12796	7904
6	13746	8579
7	12087	9994
8	12242	6789
9	11480	8818
10	11314	22577
11	11041	8059
12	12331	8898
13	9942	9288
14	11285	8573
15	11116	6410
Average $y_0$	12809	9071
Standard deviation $s_{y_0}$	2082	3869
Student's factor $t_{14; 0,95}$ (one-sided)	1,761	1,761
Slope of the calibration function	53304	53304
Intercept	7512	7512
Value at DL [Skt]	16476	15884
<b>Detection limit [<math>\mu\text{g}/\text{m}^3</math>]</b>	<b>0,2</b>	<b>0,2</b>

**Table 6.4.2:** Readings for the determination of the detection limit for GC 1561

Cycle	Before field test	After field test
	Peak area [Skt]	Peak area [Skt]
1	3841	1516
2	2961	3082
3	2562	3280
4	2923	2729
5	3331	2598
6	2394	3050
7	2394	2510
8	3145	2339
9	2193	4640
10	1606	2467
11	2555	2249
12	2644	2963
13	2312	2702
14	2811	3241
15	2384	2210
Average $y_0$	2671	2772
Standard deviation $s_{y_0}$	531	693
Student's factor $t_{14; 0,95}$ (one-sided)	1,761	1,761
Slope of the calibration function	37815	37815
Intercept	6659	6659
Value at DL [Skt]	3606	3993
<b>Detection limit [<math>\mu\text{g}/\text{m}^3</math>]</b>	<b>0,08</b>	<b>0,07</b>

## 6.5 Dependence on surrounding air temperature

### 6.5.1 Requirement according to Punkt 8.5.7 der DIN EN 14662-3 [3]

The sensitivity coefficient for the influence of the surrounding air temperature at span value shall be less than  $\pm 0,2 \text{ \%}/\text{K}$ .

### 6.5.2 Test conditions

The influence of the surrounding air temperature shall be determined at the minimum and the maximum temperature specified by the manufacturer at the operating range for the analyser.

The influence shall be determined at span concentration and at approximately 1/10 of the limit value. At each temperature setting at least 4 individual measurements for each concentration shall be performed.

The standard uncertainty caused by changes in surrounding temperature  $u_{T_s}$  is then determined:

$$u_{T_s} = \frac{b_{T_s} \cdot |\Delta T_s|}{2\sqrt{3}}$$

Where the sensitivity coefficient  $b_{T_s}$  [ $(\mu\text{g}/\text{m}^3)/\text{K}$ ] is given by:

$$b_{T_s} = \frac{|c_{T_s, \max} - c_{T_s, \min}|}{|\Delta T_s|}$$

and

$c_{T_s, \max}$  is the average of the individual measurement at maximum surrounding temperature  $T_{s, \max}$ ;

$c_{T_s, \min}$  is the average of the individual measurement at minimum surrounding temperature  $T_{s, \min}$ .

$$\Delta T_s = T_{s, \max} - T_{s, \min}$$

### 6.5.3 Assessment

The requirement of the standard is met.

### 6.5.4 Documentation

For the determination of the dependence of the zero point on the surrounding temperature the instruments were placed into a climate chamber and the following temperature sequences were set up:

20°C (3h) → 5°C (3h) → 20°C (3h) → 40°C (3h) → 20°C (5h) → 5°C (3h) → 20°C (3h) → 40°C (3h) → 20°C (5h) → 5°C (3h) → 20°C (3h) → 40°C (3h) → 20°C (3h)

After a set-up time of the climate chamber of one hour and at each temperature level span gas and zero air were applied alternately to the instruments over the period of one hour (4 test cycles). The last three test cycles of each hour were included in the analysis, the initial test cycle was considered as transitional value and rejected.

Table 6.5.1 shows the results of the tests relating to the dependence on temperature at zero concentration.

**Table 6.5.1:** Results of the tests relating to the dependence on temperature at zero concentration

Zero air	$T_{s, \max} = 40^{\circ}\text{C};$ $T_{s, \min} = 20^{\circ}\text{C}$		$T_{s, \max} = 40^{\circ}\text{C};$ $T_{s, \min} = 5^{\circ}\text{C}$		$T_{s, \max} = 20^{\circ}\text{C};$ $T_{s, \min} = 5^{\circ}\text{C}$	
	GC 1545	GC 1561	GC 1545	GC 1561	GC 1545	GC 1561
Sensitivity coefficient $b_{T_s}$ [ $\mu\text{g}/\text{m}^3 / \text{K}$ ]	0,01	0,004	0,01	0,003	0,002	0,001
Standard uncertainty $u_{T_s}$ [ $\mu\text{g}/\text{m}^3$ ]	0,07	0,02	0,08	0,03	0,01	0,004
Maximum benzene conc. $C$ [ $\mu\text{g}/\text{m}^3$ ]	0,33	0,01	0,33	0,01	0,02	-0,08
<b>Deviation <math>A</math> [<math>\mu\text{g}/\text{m}^3</math>]</b>	<b>0,26</b>	<b>0,08</b>	<b>0,28</b>	<b>0,10</b>	<b>0,02</b>	<b>0,02</b>

The deviation  $A$  is calculated according to the following equation:

$$A = c_{T_s, \max} - c_{T_s, \min}$$

To draw a comparison of the performance criterion  $K_L$  with the specification of the standard ( $K_L < \pm 0,2$  %/K) at span concentration, the measurand is calculated according to the following equation:

$$K_L = \frac{u_{T_s} \cdot 100\%}{C \cdot \Delta T_s}$$

Where

$C$ : is the maximum occurring benzene concentration [ $\mu\text{g}/\text{m}^3$ ]

Table 6.5.2 shows the results of the tests relating to the dependence on temperature at span concentration.

**Table 6.5.2:** Results of the tests relating to the dependence on temperature at span concentration

Span gas	$T_{s, \max} = 40^{\circ}\text{C};$ $T_{s, \min} = 20^{\circ}\text{C}$		$T_{s, \max} = 40^{\circ}\text{C};$ $T_{s, \min} = 5^{\circ}\text{C}$		$T_{s, \max} = 20^{\circ}\text{C};$ $T_{s, \min} = 5^{\circ}\text{C}$	
	GC 1545	GC 1561	GC 1545	GC 1561	GC 1545	GC 1561
Sensitivity coefficient $b_{T_s}$ [ $\mu\text{g}/\text{m}^3 / \text{K}$ ]	0,06	0,04	0,05	0,03	0,03	0,03
Standard uncertainty $u_{T_s}$ [ $\mu\text{g}/\text{m}^3$ ]	0,35	0,21	0,49	0,33	0,14	0,12
Maximum benzene conc. $C$ [ $\mu\text{g}/\text{m}^3$ ]	12,68	12,53	13,01	12,86	13,01	12,86
<b>Performance criterion <math>K_L</math> [% / K]</b>	<b>0,14</b>	<b>0,08</b>	<b>0,11</b>	<b>0,07</b>	<b>0,07</b>	<b>0,06</b>

## 6.6 Dependence on voltage

### 6.6.1 Requirement according to point 8.5.7 of DIN EN 14662-3 [3]

The sensitivity coefficient for the influence of voltage at span value shall be less than  $\pm 0,2 \text{ %/V}$ .

### 6.6.2 Test conditions

The dependence on line voltage shall be determined by tests at the minimum and maximum of the voltage range specified by the manufacturer, ( $V_{\max}$ ,  $V_{\min}$ ). The influence shall be determined at span concentration and at approximately 1/10 of the limit value. At least four individual measurements at each voltage level concentration shall be taken.

The standard uncertainty from voltage dependence  $u_V$  is calculated from:

$$u_V = \frac{b_V \cdot |\Delta V|}{2\sqrt{3}}$$

where the sensitivity coefficient  $b_V$  is given by:

$$b_V = \frac{|c_{V, \max} - c_{V, \min}|}{|\Delta V|}$$

and

$c_{V, \max}$  is the average of the individual measurement at maximum voltage  $V_{\max}$ ;

$c_{V, \min}$  is the average of the individual measurement at minimum voltage  $V_{\min}$ .

$$\Delta V = V_{\max} - V_{\min}$$

### 6.6.3 Assessment

The requirement of the standard is met.

### 6.6.4 Documentation

For the testing of the dependence on voltage the line voltage was changed by a variable transformer (HMW Datasystem 4.6-S). The following voltages were set up:

$$230 \text{ V} \rightarrow 210 \text{ V} \rightarrow 230 \text{ V} \rightarrow 245 \text{ V} \rightarrow 230 \text{ V}$$

At each voltage level first zero air, then span gas were applied to both gas chromatographs over the period of one hour (4 test cycles). The last three test cycles of each hour were included in the analysis, the initial test cycle was considered as transitional value and rejected.

Table 6.6.1 shows the results of the test relating to the dependence on voltage at zero concentration.

**Table 6.6.1:** Results of the test relating to the dependence on voltage at zero concentration

Zero air	$V_{\max} = 245 \text{ V};$ $V_{\min} = 230 \text{ V}$		$V_{\max} = 245 \text{ V};$ $V_{\min} = 210 \text{ V}$		$V_{\max} = 230 \text{ V};$ $V_{\min} = 210 \text{ V}$	
	GC 1545	GC 1561	GC 1545	GC 1561	GC 1545	GC 1561
Sensitivity coefficient $b_V [\mu\text{g}/\text{m}^3 / \text{V}]$	0,0025	0,000	0,0010	0,000	0,00015	0,001
Standard uncertainty $u_V [\mu\text{g}/\text{m}^3]$	0,011	0,00	0,010	0,00	0,001	0,003
Maximum benzene conc. $C [\mu\text{g}/\text{m}^3]$	-0,05	-0,11	-0,05	-0,13	-0,08	-0,11
<b>Deviation <math>A [\mu\text{g}/\text{m}^3]</math></b>	<b>0,037</b>	<b>-0,001</b>	<b>0,034</b>	<b>-0,013</b>	<b>-0,003</b>	<b>-0,012</b>

The deviation  $A$  is calculated according to the following equation:

$$A = c_{V_{\max}} - c_{V_{\min}}$$

To draw a comparison of the performance criterion  $K_L$  with the specification of the standard ( $K_L < \pm 0,2$  %/V) at span concentration, the measurand is calculated according to the following equation:

$$K_L = \frac{u_V \cdot 100\%}{C \cdot \Delta V}$$

Where

$C$ : is the maximum occurring benzene concentration [ $\mu\text{g}/\text{m}^3$ ]

Table 6.6.2 shows the results of the test relating to the dependence on voltage at span concentration.

**Table 6.6.2:** Results of the test relating to the dependence on voltage at span concentration

Prüfgas	$V_{\max} = 245 \text{ V};$ $V_{\min} = 230 \text{ V}$		$V_{\max} = 245 \text{ V};$ $V_{\min} = 210 \text{ V}$		$V_{\max} = 230 \text{ V};$ $V_{\min} = 210 \text{ V}$	
	GC 1545	GC 1561	GC 1545	GC 1561	GC 1545	GC 1561
Sensitivity coefficient $b_V [\mu\text{g}/\text{m}^3 / \text{V}]$	0,0007	0,0023	0,0015	0,0019	0,0021	0,0017
Standard uncertainty $u_V [\mu\text{g}/\text{m}^3]$	0,003	0,010	0,015	0,020	0,012	0,010
Maximum benzene conc. $C [\mu\text{g}/\text{m}^3]$	8,70	8,45	8,72	8,45	8,72	8,45
<b>Performance criterion <math>K_L</math> [% / V]</b>	<b>0,002</b>	<b>0,008</b>	<b>0,005</b>	<b>0,007</b>	<b>0,007</b>	<b>0,006</b>

## 6.7 Interference

The analyser response to certain interference, which are to be expected to be present in ambient air, shall be tested. The influence of ozone, relative humidity and organic compounds shall be determined at span concentration and at approximately 1/10 of the limit value.

### 6.7.1 Ozone

#### 6.7.1.1 Requirement according to point 8.5.9.2 of DIN EN 14662-3 [3]

The influence of the interference from ozone on the span value shall be less than  $\pm 5\%$ .

#### 6.7.1.2 Test conditions

The influence of ozone is checked by adding approximately  $180 \mu\text{g}/\text{m}^3$   $\text{O}_3$  to a standard atmosphere of benzene at span concentration.

The influence quantity of ozone  $b_{\text{O}_3}$  is calculated as follows:

$$b_{\text{O}_3} = \frac{|c_{\text{MW}, \text{O}_3} - c_{\text{MW}}|}{|c_{\text{int}, \text{O}_3}|}$$

$$u_{\text{O}_3} = b_{\text{O}_3} \cdot \sqrt{\frac{c_{\text{int}, \text{O}_3}^2}{12}} = \frac{|c_{\text{MW}, \text{O}_3} - c_{\text{MW}}|}{2 \cdot \sqrt{3}}$$

Where

$c_{\text{MW}, \text{O}_3}$  is the average of the individual measurements at maximum ozone concentration  $c_{\text{int}, \text{O}_3}$ ;

$c_{\text{MW}}$  is the average of the individual measurements without ozone.

#### 6.7.1.3 Assessment

The requirement of the standard is met.

#### 6.7.1.4 Documentation

For the determination of the interference first span gas, then zero air without any interferent was applied to the instruments over the period of one hour (4 test cycles).

Afterwards the interferent was mixed to the span gas and to the zero air over 4 test cycles, too.

In the test relating to the influence of the interferent ozone the dilution gas passed an ozone generator. Thus, ozoniferous or ozone-free span gas was generated by switching on or off the generator internal ultraviolet lamp.

Table 6.7.1.1 shows the results of the tests relating to the influence of the interferent ozone at zero concentration.

**Table 6.7.1.1:** Results of the tests relating to the influence of the interferent ozone at zero concentration

Zero air	GC 1545	GC 1561
Ozone concentration $c_{\text{int., O}_3}$ [ $\mu\text{g}/\text{m}^3$ ]	180	180
Sensitivity coefficient $b_{\text{O}_3}$	0,0004	0,0002
Standard uncertainty $u_{\text{O}_3}$ [ $\mu\text{g}/\text{m}^3$ ]	0,02	0,01
Maximum benzene conc. C [ $\mu\text{g}/\text{m}^3$ ]:	0,27	0,10
<b>Deviation [<math>\mu\text{g}/\text{m}^3</math>]</b>	<b>0,07</b>	<b>0,04</b>

To draw a comparison of the performance criterion  $K_L$  with the specification of the standard ( $K_L < \pm 5\%$ ) at span concentration, the measurand is calculated according to the following equation:

$$K_L = \frac{u_{\text{O}_3} \cdot 100\%}{C}$$

Where

C: is the maximum occurring benzene concentration [ $\mu\text{g}/\text{m}^3$ ]

Table 6.7.1.2 shows the results of the tests relating to the influence of the interferent ozone at span concentration.

**Table 6.7.1.2:** Results of the tests relating to the influence of the interferent ozone at span concentration

Zero air	GC 1545	GC 1561
Ozone concentration $c_{\text{int., O}_3}$ [ $\mu\text{g}/\text{m}^3$ ]	180	180
Sensitivity coefficient $b_{\text{O}_3}$	0,0005	0,0044
Standard uncertainty $u_{\text{O}_3}$ [ $\mu\text{g}/\text{m}^3$ ]	0,03	0,23
Maximum benzene conc. C [ $\mu\text{g}/\text{m}^3$ ]:	92,07	89,10
<b>Performance criterion <math>K_L</math> [%]</b>	<b>0,03</b>	<b>0,26</b>

## 6.7.2 Relative Humidity

### 6.7.2.1 Requirement according to point 8.5.9.3 of DIN EN 14662-3 [3]

The influence of the interference from relative humidity on the span value shall be less than  $\pm 4\%$ .

### 6.7.2.2 Test conditions

The influence of relative humidity shall be checked at 20 % and 80 % relative humidity at standard temperature and pressure. The relative uncertainty contribution  $u_{rh}(C_{test})$  is calculated from:

$$u_{rh} = \frac{b_{rh}}{2 \cdot \sqrt{3}}$$

where the sensitivity coefficient  $b_{rh}$  [ $\mu\text{g}/\text{m}^3$  / %rh] is given by:

$$b_{rh} = \frac{|c_{rh, \max} - c_{rh, \min}|}{(c_{rh, \max} + c_{rh, \min}) \cdot 0,5} \cdot 100\% \text{ "rh} =$$

and

$c_{rh, \max}$  is the average of the individual measurements at maximum relative humidity  $c_{int., rh, \max}$ ;

$c_{rh, \min}$  is the average of the individual measurements at minimum relative humidity  $c_{int., rh, \min}$ .

### 6.7.2.3 Assessment

The requirement of the standard is met.

### 6.7.2.4 Documentation

For the determination of the interference first span gas, then zero air without humidity was applied to the instruments over the period of one hour (4 test cycles).

Afterwards the interferent was mixed to the span gas and to the zero air over 4 test cycles, too. The dilution gas passed a nafion membrane, which is humidified in the counter flow by distilled water. A defined humidity is regulated by the temperature of the water quench.

Table 6.7.2.1 shows the results of the test relating to the influence of the interferent water vapour at zero concentration.

**Table 6.7.2.1:** Results of the test relating to the influence of the interferent water vapour at zero concentration

Zero air	GC 1545	GC 1561
Relative humidity zero air (dry) [%rh]	3,8	3,8
Relative humidity zero air (humid) [%rh]	81,7	81,7
Sensitivity coefficient $b_{rh}$ [ $\mu\text{g}/\text{m}^3$ ]/%rh]	16,1	12,1
Standard uncertainty $u_{rh}$ [ $\mu\text{g}/\text{m}^3$ ]	4,6	3,5
Maximum benzene conc. C [ $\mu\text{g}/\text{m}^3$ ]:	-0,04	-0,15
<b>Deviation [<math>\mu\text{g}/\text{m}^3</math>]</b>	<b>-0,01</b>	<b>-0,02</b>

To draw a comparison of the performance criterion  $K_L$  with the specification of the standard ( $K_L < \pm 4 \%$ ) at span concentration, the measurand is calculated according to the following equation:

$$K_L = \frac{u_{rh} \cdot 100\%}{C}$$

where

C: is the maximum occurring benzene concentration [ $\mu\text{g}/\text{m}^3$ ]

Table 6.7.2.2 shows the results of the test relating to the influence of the interferent water vapour at span concentration. For the calculation of the difference between the readings of the „dry“ and the „humid“ span gases the reading of the „humid“ span gas was corrected according to the volumetric content of water vapour in the dilution gas.

**Table 6.7.2.2:** Results of the test relating to the influence of the interferent water vapour at span concentration

Zero air	GC 1545	GC 1561
Relative humidity zero air (dry) [%rh]	4,0	4,0
Relative humidity zero air (humid) [%rh]	81,1	81,1
Sensitivity coefficient $b_{rh}$ [ $\mu\text{g}/\text{m}^3$ ]/%rh]	0,4	1,2
Standard uncertainty $u_{rh}$ [ $\mu\text{g}/\text{m}^3$ ]	0,1	0,4
Maximum benzene conc. C [ $\mu\text{g}/\text{m}^3$ ]:	87,47	84,77
<b>Performance criterion <math>K_L</math> [%]</b>	<b>0,13</b>	<b>0,42</b>

### 6.7.3 Organic compounds

#### 6.7.3.1 Requirement according to point 8.5.9.4 of DIN EN 14662-3 [3]

The influence of the interference from organic compound on the span value shall be less than  $\pm 5\%$ .

#### 6.7.3.2 Test conditions

Possible interference from organic compounds shall be investigated by a gas mixture of different organic compounds at concentrations of about  $3 \mu\text{g}/\text{m}^3$  to  $10 \mu\text{g}/\text{m}^3$  for each compound.

The relative uncertainty from interferences  $u_{c, \text{org}}$  is calculated from:

$$u_{c_{\text{org}}} = \frac{|c_{MW, \text{org}} - c_{MW}|}{\sqrt{3}}$$

Where the influence  $b_{\text{org}}$  is given by

$$b_{\text{org}} = \frac{|c_{MW, \text{org}} - c_{MW}|}{|c_{MW}|}$$

and

$c_{MW, \text{org}}$  is the average of the individual measurements in the presence of the gas mixture selected;

$c_{MW}$  is the average of the individual measurements without interference.

#### 6.7.3.3 Assessment

The requirement of the standard is not met without qualification.

Qualification:

Under the influence of tetrachlormethane both gas chromatographs show a negative result for benzene, dependent on the concentration of the interferent.

At a concentration of tetrachloromethane of more than  $1,5 \mu\text{g}/\text{m}^3$  both instruments show a distinct interference on the present test conditions.

#### 6.7.3.4 Documentation

For the determination of the interference initially span gas, then zero air without presence of interferents were applied to the instruments over the period of one hour (4 test cycles).

Afterwards the interferents were mixed to the span gas and to the zero air over 4 test cycles, too.

The organic compounds were mixed to the benzene span gas by a thermal mass flow controller (MFC) with a volume flow of  $2 \text{ ml}/\text{min}$ . Since the span gas volume flow of  $3,9 \text{ l}/\text{min}$  was considerably higher (by factor 2000) a correction of the initial concentration was in this case not necessary.

Following compounds were applied:

- Mixture of: tetrachlormethane, cyclohexane, trichlorethylene, n-heptane
- 2-methylhexane
- methylcyclopentane
- 2,4-dimethylpentane

The tables 6.7.3.1 and 6.7.3.2 show the results of the tests relating to the interference from organic compounds at zero concentration.

**Table 6.7.3.1:** Results of the tests relating to the interference from organic compounds at zero concentration (Synthec GC 1545)

Interferent	Conc. [ $\mu\text{g}/\text{m}^3$ ]	Sensitivity coefficient $b_{\text{org}}$	Standard uncertainty $u_{\text{c, org}}$ [ $\mu\text{g}/\text{m}^3$ ]	Maximum benzene concentration C [ $\mu\text{g}/\text{m}^3$ ]	Dev. [ $\mu\text{g}/\text{m}^3$ ]
Isoheptane	13,5	0,29	0,004	0,05	-0,006
Methylcyclopentane	12,4	0,26	0,004	-0,06	0,006
2,4-dimethylpentane	15,3	1,36	0,025	0,03	0,043
Tetrachlormethane n-heptane Trichlorethylene Cyclohexane	34,7 7,4 9,7 6,2	0,41	0,008	-0,07	0,015

**Table 6.7.3.2:** Results of the tests relating to the interference from organic compounds at zero concentration (Synthec GC 1561)

Interferent	Conc. [ $\mu\text{g}/\text{m}^3$ ]	Sensitivity coefficient $b_{\text{org}}$	Standard uncertainty $u_{\text{c, org}}$ [ $\mu\text{g}/\text{m}^3$ ]	Maximum benzene concentration C [ $\mu\text{g}/\text{m}^3$ ]	Dev. [ $\mu\text{g}/\text{m}^3$ ]
Isoheptane	13,5	0,35	0,013	-0,03	0,022
Methylcyclopentane	12,4	0,01	0,001	-0,12	-0,002
2,4-dimethylpentane	15,3	0,52	0,039	-0,02	0,068
Tetrachlormethane n-heptane Trichlorethylene Cyclohexane	34,7 7,4 9,7 6,2	0,15	0,011	-0,10	0,019

To draw a comparison of the performance criterion  $K_L$  with the specification of the standard ( $K_L < \pm 5\%$ ) at span concentration, the measurand is calculated according to the following equation:

$$K_L = \frac{u_{c,org} \cdot 100\%}{C}$$

Where

C: is the maximum occurring benzene concentration [ $\mu\text{g}/\text{m}^3$ ]

The tables 6.7.3.3 and 6.7.3.4 show the results of the tests relating to the interference from organic compounds at span concentration.

**Table 6.7.3.3:** Results of the tests relating to the interference from organic compounds at span concentration (Synthec GC 1545)

Interferent	Conc. [ $\mu\text{g}/\text{m}^3$ ]	Sensitivity coefficient $b_{org}$	Standard uncertainty $u_{c,org}$ [ $\mu\text{g}/\text{m}^3$ ]	Maximum benzene conc. C [ $\mu\text{g}/\text{m}^3$ ]	Performance criterion $K_L$ [%]
Isoheptane	13,5	0,003	0,13	87,91	0,15
Methylcyclopentane	12,4	0,01	0,36	87,84	0,41
2,4-dimethylpentane	15,3	0,005	0,23	86,74	0,26
Tetrachlormethane n-heptane Trichlorethylene Cyclohexane	34,7 7,4 9,7 6,2	0,51	25,22	86,25	29,25

**Table 6.7.3.4:** Results of the tests relating to the interference from organic compounds at span concentration (Synthec GC 1561)

Interferent	Conc. [ $\mu\text{g}/\text{m}^3$ ]	Sensitivity coefficient $b_{org}$	Standard uncertainty $u_{c,org}$ [ $\mu\text{g}/\text{m}^3$ ]	Maximum benzene conc. C [ $\mu\text{g}/\text{m}^3$ ]	Performance criterion $K_L$ [%]
Isoheptane	13,5	0,007	0,33	84,11	0,39
Methylcyclopentane	12,4	0,01	0,49	84,60	0,58
2,4-dimethylpentane	15,3	0,004	0,18	82,99	0,21
Tetrachlormethane n-heptane Trichlorethylene Cyclohexane	34,7 7,4 9,7 6,2	0,51	24,05	81,75	29,42

The tables 6.7.3.3 and 6.7.3.4 reveal, that the requirement of DIN EN 14662-3 [3] relating to the component mixture (tetrachlormethane, cyclohexane, trichlorethylene, n-heptane) is not met. A closer examination of the chromatograms concerned showed, that the component tetrachlormethane caused a negative result for benzene (lowering of the base line). Due to this result a further test was carried out with interferent concentrations ( $35 \mu\text{g}/\text{m}^3$ ) decreased to maximum values occurring in ambient air ( $1,4 - 3,6 \mu\text{g}/\text{m}^3$ ). The following relations turned out:

**Table 6.7.3.5:** Results of the supplementary test of interference from tetrachlormethane (Synthec GC 1545)

Interferent	Conc. [ $\mu\text{g}/\text{m}^3$ ]	Sensitivity coefficient $b_{\text{org}}$	Standard uncertainty $u_{\text{c, org}}$ [ $\mu\text{g}/\text{m}^3$ ]	Maximum benzene conc. C [ $\mu\text{g}/\text{m}^3$ ]	Performance criterion $K_L$ [%]
Tetrachlormethane n-heptane Trichlorethylene Cyclohexane	3,6 0,8 1,0 0,6	0,08	3,88	81,78	4,7
Tetrachlormethane n-heptane Trichlorethylene Cyclohexane	1,4 0,3 0,4 0,3	0,02	0,97	81,78	1,2
Tetrachlormethane n-heptane Trichlorethylene Cyclohexane	1,4 0,3 0,4 0,3	0,04	0,72	29,08	2,5
Tetrachlormethane n-heptane Trichlorethylene Cyclohexane	3,6 0,8 1,0 0,6	0,11	1,77	29,08	6,1

**Table 6.7.3.5:** Results of the supplementary test of interference from tetrachlormethane (Synthec GC 1561)

Interferent	Conc. [ $\mu\text{g}/\text{m}^3$ ]	Sensitivity coefficient $b_{\text{org}}$	Standard uncertainty $u_{\text{c, org}}$ [ $\mu\text{g}/\text{m}^3$ ]	Maximum benzene conc. C [ $\mu\text{g}/\text{m}^3$ ]	Performance criterion $K_L$ [%]
Tetrachlormethane n-heptane Trichlorethylene Cyclohexane	3,6 0,8 1,0 0,6	0,13	5,90	76,65	7,7
Tetrachlormethane n-heptane Trichlorethylene Cyclohexane	1,4 0,3 0,4 0,3	0,05	2,39	76,65	3,1
Tetrachlormethane n-heptane Trichlorethylene Cyclohexane	1,4 0,3 0,4 0,3	0,07	1,04	27,10	3,8
Tetrachlormethane n-heptane Trichlorethylene Cyclohexane	3,6 0,8 1,0 0,6	0,16	2,49	27,10	9,2

The results indicate that both gas chromatographs have an interference from the organic compound tetrachlormethane, which causes a distinct negative result for benzene, depending on the interferent's concentration.

## 6.8 Carry-over (memory effect)

### 6.8.1 Requirement according to point 8.5.10 of DIN EN 14662-3 [3]

The benzene concentration of the second analysis of zero air immediately following the analysis of the highest benzene concentration shall be less than  $0,5 \mu\text{g}/\text{m}^3$  (= 10 % of the limit value).

### 6.8.2 Test conditions

During the linearity test the influence of a memory effect caused by the retention of benzene in the measuring system due to inappropriate materials or a large dead volume is checked.

The second analysis of zero air immediately following the analysis of the highest concentration of benzene (70 – 80 % of the maximum of the certification range) required for the linearity test shall not exceed a measured benzene concentration of 10 % of the limit value ( $0,5 \mu\text{g}/\text{m}^3$ ).

### 6.8.3 Assessment

The requirement of the standard is met.

### 6.8.4 Documentation

The values determined during the lack of fit were used for the determination of the memory effect. Five different span gas concentrations over the measurement range up to  $50 \mu\text{g}/\text{m}^3$  as well as zero concentration were applied to both gas chromatographs by means of the gas mix apparatus as described in paragraph 4.1. A benzene concentration over the range of 75 % of the span level (about  $38 \mu\text{g}/\text{m}^3$ ) and subsequently zero air were applied. Each concentration was applied over the period of one hour (4 test cycles of 15 minutes = 4 readings) with five successive calibration cycles. The first two zero air values (ZAV) following the previous high benzene concentration are indicated in table 6.8.1 below.

**Table 6.8.1:** Results of the determination of the memory effect

Cycle	GC 1545		GC 1561	
	1. ZAV	2. ZAV	1. ZAV	2. ZAV
1	0,30	<b>0,07</b>	-0,01	<b>-0,08</b>
2	0,20	<b>0,02</b>	-0,01	<b>-0,08</b>
3	0,19	<b>0,14</b>	0,04	<b>-0,08</b>
4	0,13	<b>0,09</b>	-0,02	<b>-0,10</b>
5	0,22	<b>0,03</b>	0,04	<b>-0,07</b>

## 6.9 Long term drift

### 6.9.1 Requirement according to point 8.6.5 of DIN EN 14662-3 [3]

The largest value of the long term drift at span value  $d_{14d}$  during the field test over a drift period of 14 days shall be less than  $\pm 10\%$ .

### 6.9.2 Test conditions

Long term drift is evaluated from the averages of 4 independent measurements at the span concentration, with these sets of measurements performed at intervals of 14 days.

The long term drift is calculated as follows:

$$d_{14d} = \frac{|c_{MW,n} - c_{MW,n-1}|}{c_{MW,n}} \cdot 100\%$$

where

$d_{14d}$  is the drift span concentration  $c_t$  as percentage;

$c_{MW,n}$  is the average of the 4 analyses at the beginning of the drift period;

$c_{MW,n-1}$  is the average of the 4 analyses at the end of the drift period (14 d).

The uncertainty  $u_d$  due to the long term drift at span value shall be calculated as follows:

$$u_d = \frac{|c_{MW,n} - c_{MW,n-1}|}{2 \cdot \sqrt{3}}$$

### 6.9.3 Assessment

The requirement of the standard is met.

### 6.9.4 Documentation

For the determination of the long term drift zero air and span gas at a benzene concentration of  $10,8 \mu\text{g}/\text{m}^3$  were applied at intervals of 25 h and for 45 minutes (3 test cycles) each. The last two test cycles were included in the analysis, each initial test cycle was considered as transitional value and rejected. The application of zero air and span gas was carried out by means of a computer-controlled valve unit (see paragraph 4.2). The following malfunctions caused three failure periods during the test:

Failure 1: Malfunction of the compressor for the zero air treatment

Failure 2: Malfunction of the computer unit for the automatic valve control for the application of zero air and span gas

Failure 3: Malfunction of the compressor for the zero air treatment

However, these failure periods did not have an impact on the operation and on the availability (see paragraph 6.26) of both analysers, as the measuring of the ambient air continued regularly during these failures.

The results of the tests relating to the drift of the span value are depicted by the graph as well as by the table below.

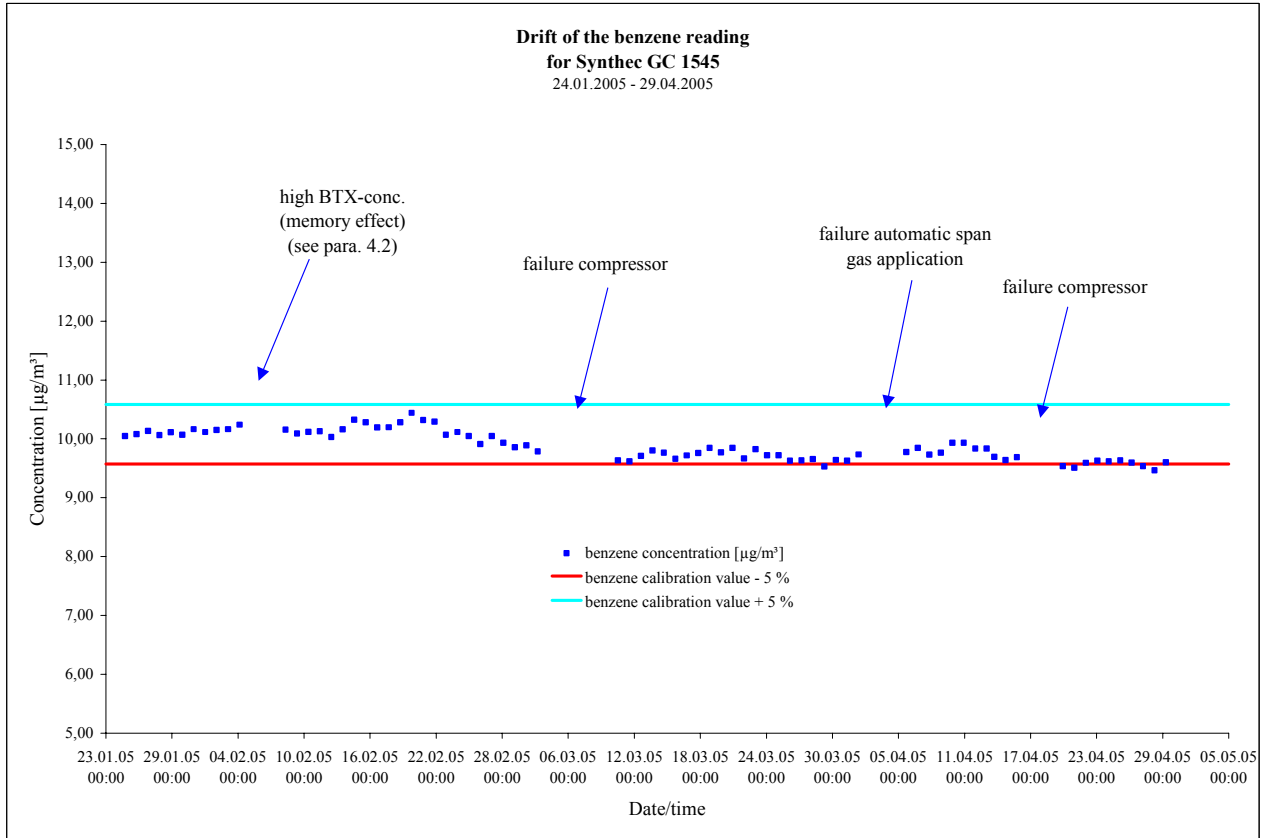

**Fig. 6.9.1:** Drift of the reading for GC 1545

**Table 6.9.1:** Calculation of the long term drift (14 d) of the reading (specified value:  $10,08 \mu\text{g}/\text{m}^3$ )

	GC 1545			GC 1561		
	[ $\mu\text{g}/\text{m}^3$ ]	$d_{14d}$ [%]	$u_d$ [ $\mu\text{g}/\text{m}^3$ ]	[ $\mu\text{g}/\text{m}^3$ ]	$d_{14d}$ [%]	$u_d$ [ $\mu\text{g}/\text{m}^3$ ]
Average	9,88	<b>1,58</b>	0,05	9,47	<b>1,83</b>	0,05
Maximum value	10,44	<b>4,76</b>	0,14	10,07	<b>4,29</b>	0,12
Minimum value	9,46	<b>0,09</b>	0,00	8,75	<b>0,05</b>	0,00

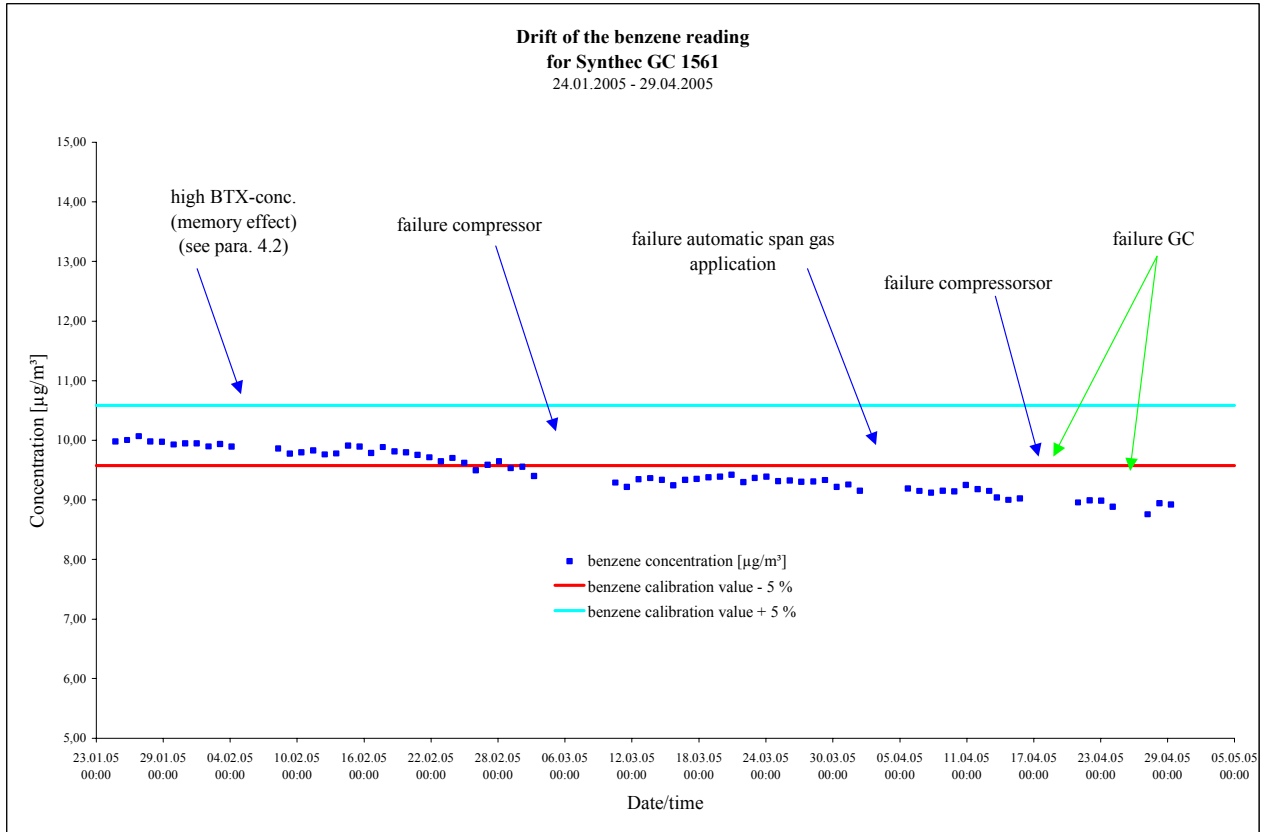

**Fig. 6.9.2:** Drift of the reading for GC 1561

The figures 6.18.1 and 6.18.2 show, that both gas chromatographs had a noticeable drift. After 33 days the allowable drift of the readings of GC 1561 was under-run. This under-run of the tolerance limit is at the same time the indicator for the determination of the maintenance interval (see paragraph 6.27).

## 6.10 Maintenance interval

### 6.10.1 Requirement according to point 8.6.6 of DIN EN 14662-3 [3]

The maintenance interval shall be at least two weeks. During this period the analyser shall not need any regular maintenance or adjustment.

### 6.10.2 Test conditions

During this test it is to be investigated, which maintenance jobs in which intervals are necessary for the correct operability of the test equipment. If extensive maintenance jobs for the instruments are not necessary in short time periods, the maintenance interval results predominantly from the drift of the test equipment (see paragraph 6.17 und 6.18).

### 6.10.3 Assessment

During the duration of the field test (3 months) maintenance jobs were not necessary. The consumption of carrier gas (nitrogen 5.0) was about 8 ml/min per instrument. Thus, the durability of a 10 litre compressed gas cylinder is about 6 months.

The maintenance interval is consequently determined by the drift of the instruments. The field tests showed, that after 33 days the allowable drift of the readings of GC 1561 was under-run (see paragraph 6.18).

On the basis of these results, the maintenance has to be carried out not later than after 4 weeks. Additionally, an annual general overhaul of the gas chromatographs by the manufacturer is recommended.

#### NOTE:

Our experiences in the measurement network reveal, that the immission concentration of benzene at the different gauging stations amount from 0  $\mu\text{g}/\text{m}^3$  to 10  $\mu\text{g}/\text{m}^3$  maximum. We therefore recommend to perform a basic calibration of the gas chromatograph with at least five calibration points over the range of 0 – 20  $\mu\text{g}/\text{m}^3$ .

### 6.10.4 Documentation

See paragraph 6.9.

## 6.11 Availability

### 6.11.1 Requirement according to point 8.6.7 of DIN EN 14662-3 [3]

The availability  $A_a$  of the test equipment has to be at least 90 %.

### 6.11.2 Test conditions

Checks on the correct operation of the instruments shall be made at least every 14 days. It is recommended that these checks are performed daily. The time, duration and nature of any abnormalities shall be recorded.

The total time during the field test for which valid measurement data of the ambient air concentrations are obtained is used to calculate the availability. The time needed for calibrations, conditioning of sample lines and filters, and maintenance shall not be included in the field test period.

The data coverage is calculated as

$$A_a = \frac{t_u}{t_t} \cdot 100\%$$

where

$A_a$  is the availability of the analyser;

$t_u$  is the total time period with validated measuring data;

$t_t$  is the time period of the field tests minus the time spent on zero and span check, and on maintenance.

### 6.11.3 Assessment

The requirement of the standard is met.

### 6.11.4 Documentation

The field test was carried out from January 24th 2005 to April 29th 2005 on the test site of UMEG. During this period, an operation control was performed every 25 hours by external application of zero air and span gas. The application was effected by means of a computer-controlled valve unit (see paragraph 4.2).

Two relevant failures of GC 1561 occurred during the field test for the following reasons:

1. Malfunction of the stepping motor of the sampling piston (04/19/05 – 04/20/05)

This sampling piston is an essential element for the sampling procedure. It attracts air samples and concentrates them on the absorption column. This procedure takes place several times per test cycle, according to the programming. The malfunction of the stepping motor affected the stroke. According to the instructions given by Synspec this problem could be solved by placing back manually the motor to its initial position.

2. Error message „Error precontemperature“ (04/24/05 – 04/26/05)

The error message „Error precontemperature“ refers to the fact, that the power requirement for the heating of the sample loop is out of the specified temperature range. In this case the instrument cancels the measurements self-controlled for safety reasons. The error did not occur again after a manual re-start.

Both gas chromatographs had sporadic failures of a test cycle (15 minutes), which effected without any obvious cause an incorrect chromatogram and a failure of the relevant reading. The following chromatograms were correct.

Over the entire period of the field test (3 months) GC 1545 had 18 failures (= 4,5 h) and GC 1561 had 8 failures (= 2 h).

The results are resumed in table 6.11.1.

**Table 6.11.1:** Results relating to the evaluation of the availability  $A_a$  of both instruments.

		<b>GC 1545</b>	<b>GC 1561</b>
Operation time $t_E$	[h:min]	2274:30	2274:30
Calibration time $t_K$	[h:min]	133:30	129:00
Failure time $t_A$	[h:min]	04:30	74:15
Maintenance $t_W$	[h:min]	-	-
<b>Availability <math>A_a</math></b>	<b>[%]</b>	<b>99,8</b>	<b>96,6</b>

With:  $t_u = t_E - t_A - t_K - t_W$

and  $t_t = t_E - t_K - t_W$

## 6.12 Reproducibility standard deviation under field conditions

### 6.12.1 Requirement according to point 8.6.8 of DIN EN 14662-3 [3]

The reproducibility standard deviation under field conditions  $s_{Rf}$  of both instruments shall be less than  $\pm 0,25 \mu\text{g}/\text{m}^3$ .

### 6.12.2 Test conditions

The reproducibility standard deviation under field conditions is calculated from the parallel measurement data obtained during the field test.

The difference for each parallel measurement  $i$  is calculated from:

$$d_{f,i} = (c_{1,f})_i - (c_{2,f})_i$$

The average difference from these measurements is calculated from:

$$(d_f)_{MW} = \frac{\sum d_{f,i}}{n}$$

Where

- $d_{f,i}$  is the  $i$ -th difference in a parallel measurement;
- $(c_{1,f})_i$  is the  $i$ -th measurement result of analyser 1;
- $(c_{2,f})_i$  is the  $i$ -th measurement result of analyser 2;
- $n$  is the number of parallel measurements.

The reproducibility standard deviation (under field conditions)  $s_{Rf}$  is calculated according to

$$s_{Rf} = \sqrt{\frac{\sum d_{f,i}^2}{2n}}$$

The standard uncertainty according to the reproducibility in the field is calculated as

$$u_{Rf} = s_{Rf}$$

### 6.12.3 Assessment

The requirement of the standard is met.

### 6.12.4 Documentation

The analysis bases on an amount of data of 289 value pairs, extracted from the totality of the surrounding air readings evaluated during the field test, with a concentration between  $7 \mu\text{g}/\text{m}^3$  and  $12 \mu\text{g}/\text{m}^3$ .

The resulting data for the calculation of the reproducibility standard deviation are resumed in the following table 6.12.1.

**Table 6.12.1:** Data for the calculation of the reproducibility standard deviation during the field test

	<b>GC 1545 und GC 1561</b>
Measurement range	7 - 12 $\mu\text{g}/\text{m}^3$
Number of value pairs n	289
Reading <sub>GC 1545</sub>	9,15 $\mu\text{g}/\text{m}^3$
Reading <sub>GC 1561</sub>	9,04 $\mu\text{g}/\text{m}^3$
<b><math>u_{Rf} = s_{Rf} [\mu\text{g}/\text{m}^3]</math></b>	<b>0,23</b>

## 6.13 Total uncertainty according to paragraph 8.7 of DIN EN 14662-3 [3]

### 6.13.1 Requirement according to paragraph 8.7 of DIN EN 14662-3 [3]

The expanded uncertainty of the analyser shall be evaluated. The determined value may not exceed the specifications of the EU directive [8] relating to the ambient air quality (data quality requirements: for benzene a maximum value of 25 % for the expanded uncertainty as percentage is allowable in continuous measurements).

### 6.13.2 Test conditions

The total uncertainty of the readings of the instrument is to be compiled for the performance characteristics of the instrument determined in the suitability evaluation.

The total uncertainty calculation is performed in two steps:

- 1) calculation of the total uncertainty with the values of the performance characteristics determined in the laboratory tests;
- 2) re-calculation of the total uncertainty found in 1) using the field test by replacing the values for the short term drift from the laboratory test by the values for the long term drift of the field test and by replacing the values for the repeatability (from the laboratory test) by the value of the reproducibility in the field.

The combined uncertainty is estimated from the contribution of the individual contributions in accordance with the following equation:

$$u_c = c_{test} \sqrt{\sum \frac{u_i^2}{c_i^2}}$$

where

$u_c$  is the combined uncertainty connected to the concentration of benzene;

$u_i$  is the partial contribution of the standard uncertainty at concentration  $c_i$ .

The expanded uncertainty at the 95 % confidence level is obtained by multiplying  $u_c$  with a coverage factor of 2.

### 6.13.3 Assessment

The requirement of the standard is met.

### 6.13.4 Documentation

The calculation of the total uncertainty was performed according to the specifications of DIN EN 14662-3 [3], especially to the example in annex B of the standard. Table 6.13.1 shows the total uncertainty  $u_c/c$ , which was calculated by means of the performance characteristics determined in the laboratory tests.

#### Note:

In the calculation of the uncertainty of the interference from organic interferents the values of the component tetrachlormethane were included at a concentration of 1,4  $\mu\text{g}/\text{m}^3$  (see qualification in paragraph 6.7.3).

**Table 6.13.1:** Total uncertainty  $u_c/c$  for the laboratory test

Total uncertainty for the laboratory test		GC 1545	GC1561		GC 1545	GC1561
Uncertainty of the span gas*	$u_{\text{span}} [\mu\text{g}/\text{m}^3]$	0,12	0,12	$c_{\text{Benzene}}[\mu\text{g}/\text{m}^3]$	10,08	10,08
Lack of fit	$u_{\text{fit}} [\mu\text{g}/\text{m}^3]$	0,078	0,045	$c_{\text{Benzene}}[\mu\text{g}/\text{m}^3]$	26,44	7,16
Repeatability	$u_r [\mu\text{g}/\text{m}^3]$	0,02	0,05	$c_{\text{Benzene}}[\mu\text{g}/\text{m}^3]$	6,71	7,10
Interference from ozone	$u_{\text{O}_3} [\mu\text{g}/\text{m}^3]$	0,03	0,23	$c_{\text{Benzene}}[\mu\text{g}/\text{m}^3]$	92,07	89,10
Interference from organic compounds	$u_{\text{org}} [\mu\text{g}/\text{m}^3]$	0,72	1,04	$c_{\text{Benzene}}[\mu\text{g}/\text{m}^3]$	29,08	27,10
Interference from relative humidity	$u_{\text{rh}} [\mu\text{g}/\text{m}^3]$	0,11	0,35	$c_{\text{Benzene}}[\mu\text{g}/\text{m}^3]$	87,47	84,77
Dependence on the surrounding temperature	$u_{\text{Ts}} [\mu\text{g}/\text{m}^3]$	0,49	0,33	$c_{\text{Benzene}}[\mu\text{g}/\text{m}^3]$	13,01	12,86
Dependence on voltage	$u_v [\mu\text{g}/\text{m}^3]$	0,01	0,02	$c_{\text{Benzene}}[\mu\text{g}/\text{m}^3]$	8,72	8,45
Short term drift	$u_s [\mu\text{g}/\text{m}^3]$	0,09	0,14	$c_{\text{Benzene}}[\mu\text{g}/\text{m}^3]$	47,26	47,33
<b>Total uncertainty <math>u_c/c</math> [%]</b>		<b>4,7</b>	<b>4,9</b>			
<b>Expanded uncertainty <math>U_{c, \text{rel}}</math> [%]</b>		<b>9,4</b>	<b>9,8</b>			

\*: The uncertainty of the generation of the span gas is  $\pm 2\%$  (in relation to  $10 \mu\text{g}/\text{m}^3$ ). Standard method verified for several years.

Table 6.13.2 shows the total uncertainty  $u_c/c$  for the field test.

**Table 6.13.2:** Total uncertainty  $u_c/c$  for the field tests

Total uncertainty for the field test		GC 1545	GC1561		GC 1545	GC1561
Uncertainty of the span gas *	$u_{\text{span}} [\mu\text{g}/\text{m}^3]$	0,12	0,12	$c_{\text{Benzene}}[\mu\text{g}/\text{m}^3]$	10,08	10,08
Lack of fit	$u_{\text{fit}} [\mu\text{g}/\text{m}^3]$	0,078	0,045	$c_{\text{Benzene}}[\mu\text{g}/\text{m}^3]$	26,44	7,16
Reproducibility stand. deviation	$u_{\text{rf}} [\mu\text{g}/\text{m}^3]$	0,23	0,23	$c_{\text{Benzene}}[\mu\text{g}/\text{m}^3]$	9,15	9,04
Interference from ozone	$u_{\text{O}_3} [\mu\text{g}/\text{m}^3]$	0,03	0,23	$c_{\text{Benzene}}[\mu\text{g}/\text{m}^3]$	92,07	89,10
Interference from organic compounds	$u_{\text{org}} [\mu\text{g}/\text{m}^3]$	0,72	1,04	$c_{\text{Benzene}}[\mu\text{g}/\text{m}^3]$	29,08	27,10
Interference from relative humidity	$u_{\text{rh}} [\mu\text{g}/\text{m}^3]$	0,11	0,35	$c_{\text{Benzene}}[\mu\text{g}/\text{m}^3]$	87,47	84,77
Dependence on the surrounding temperature	$u_{\text{Ts}} [\mu\text{g}/\text{m}^3]$	0,49	0,33	$c_{\text{Benzene}}[\mu\text{g}/\text{m}^3]$	13,01	12,86
Dependence on voltage	$u_v [\mu\text{g}/\text{m}^3]$	0,01	0,02	$c_{\text{Benzene}}[\mu\text{g}/\text{m}^3]$	8,72	8,45
Long term drift	$u_d [\mu\text{g}/\text{m}^3]$	0,14	0,12	$c_{\text{Benzene}}[\mu\text{g}/\text{m}^3]$	10,44	10,07
<b>Total uncertainty <math>u_c/c</math> [%]</b>		<b>5,5</b>	<b>5,6</b>			
<b>Expanded uncertainty <math>U_{c, \text{rel}}</math> [%]</b>		<b>11,0</b>	<b>11,2</b>			

\*: The uncertainty of the generation of the span gas is  $\pm 2\%$  (in relation to  $10 \mu\text{g}/\text{m}^3$ ). Standard method verified for several years.

## 7 Bibliography

- [1] VDI directive 4202 part 1: Minimum requirements for suitability tests of automated ambient air quality measuring systems point-related measurement methods of gaseous and particulate pollutants; June 2002; Beuth-Verlag Berlin
- [2] VDI directive 4203 part 3: Testing of automated measuring systems; Test procedures for point-related ambient air quality measuring systems of gaseous and particulate pollutants; August 2004; Beuth-Verlag Berlin
- [3] DIN EN 14662 - 3: Ambient Air Quality - Standard method for the measurement of benzene concentrations - Part 3: Automated pumped sampling with in situ gas chromatography; August 2005; Beuth-Verlag Berlin
- [4] UMEG report 53-3/05: *Bericht über die Eignungsprüfung des Gaschromatographen GC 955 Modell 601 der Fa. Synspec*; August 2005
- [5] VDI directive 3490 part 16: Measurement of Gases; Calibration Gas Mixtures; Dynamic Preparation with Critical Orifice Systems; October 1994; Beuth-Verlag Berlin
- [6] VDI directive 3490 part 8: Measurement of Gases; Calibration Gas Mixtures; Preparation by Continuous Injection Method; January 1981; Beuth-Verlag Berlin
- [7] DIN EN ISO/IEC 17025: General requirements for the competence of testing and calibration laboratories; April 2000; Beuth-Verlag Berlin
- [8] Directive 2000/69/EC of the European Parliament and of the Council of 16.November 2000 relating to limit values for benzene and carbon monoxide in ambient; Abl. Nr. L313, p. 12